

# 0/1 SERIES IC/REMODEL

## RECESSED LED DOWNLIGHT HOUSINGS AND TRIMS

### INSTALLATION

Before beginning any DOWNLIGHT installation, disconnect electrical power at main switch or circuit breaker.

#### A. CAUTION

To reduce the risk of fire, electric shock, and potential damage to recessed housing assembly when electrical power is re-connected, DO NOT ATTEMPT TO CONNECT the following on branch circuit serving recessed downlight assembly:

- Motors
- Power tools
- Extension cords
- Appliances or similar electronics

Housings to be mounted in ceiling / plenum conditions *where ambient temperatures do not exceed 40°C unless otherwise noted as 35°C on specification sheets.*

Lucifer Lighting LED housings must be used with Lucifer Lighting LED downlights.

#### C. WIRING - GENERAL NOTES

The downlight fitting assembly should be installed by a registered electrician and shall comply with national and local codes and ordinances.

The installer of the downlight fitting assembly is responsible for furnishing proper electrical equipment and materials for the installation of the downlights as intended by these installation instructions. Install downlight fitting and supply sufficient length mains voltage wiring to permit access to components and splice connections, which may require future servicing.

Metal conduit shall be used if required by applicable codes. Must use 90°C-rated supply wire only. The conductor insulation must feature the appropriate temperature rating as specified on the label for each Lucifer Lighting Company downlight assembly. Attach protective earth grounds to driver, as apply. No part of the secondary circuit shall be grounded. For systems that will be dimmed, consult controls manufacturer to verify driver compatibility and proper installation procedures and parameters.

### B. SAFETY INSTRUCTIONS

1. Read installation instructions completely before attempting installation.
2. Failure to follow instructions may result in improper installation and void warranty.
3. Contact Lucifer Lighting Company with any questions or concerns before beginning any installation.
4. Ensure qualified electrician will perform all electrical procedures.
5. Disconnect electrical power circuit before attempting to install recessed downlight housing or trim, or if adding to or changing configuration of downlight housing or trim assembly.
6. Install / mount recessed downlight housing on structurally sound surface.
7. Recessed downlight housings may be installed in dry or damp locations only.
8. **IC housing allows for:**  
**Direct contact with** polycell spray-in foam insulation having max R-Value of 60 allowed on all sides and top of housing. No plenum setback requirements beyond fixture fitment.
9. **Consult factory for spacing requirements for any installations exceeding R-Value of 60.**

**LUCIFER**<sup>®</sup>  
LIGHTING COMPANY

## D. HOUSING INSTALLATION

### 1.1 KEY HOUSING COMPONENTS

**Note:** Housing aperture is equipped with a disposable foam plug to minimize dust / paint invasion. Remove prior to appliqué installation.

Become familiar with the wiring compartment access points, hanger bar assemblies, and housing collar features associated with the IC and Non-IC housing platforms.

Access panel (*Fig.1*) provides access to wiring compartment prior to installation of ceiling substrate and is retained with screws. Driver assembly held in place with spring tab (*Fig.2*). See Section G for instructions on servicing driver and wiring compartment from below and through housing aperture.

**Note:** Housing lid and cover plate are not removable in the field.

Base collar plate for square fixtures can be rotated up to 45° to ensure proper alignment. Secure collar to prevent rotation using locking screw on bottom of housing (*Fig.3*).

### 1.2 HANGER BAR ASSEMBLIES

Hanger bars extend from 14" (356mm) to 24" (610mm) centers and mount to either short or long axis of housing. To install hanger bars on housing, slide mating halves together, joining through mounting bracket on housing sides. Secure position with locking screws (*Fig.4*).

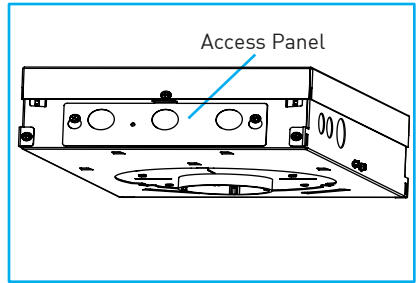

Fig.1

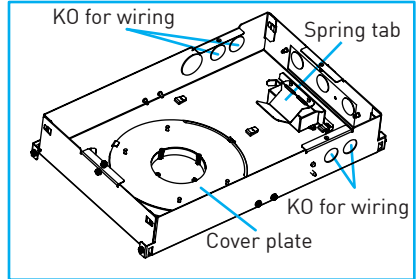

Fig.2

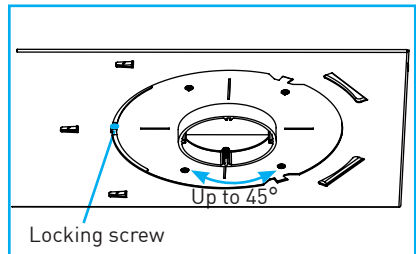

Fig.3

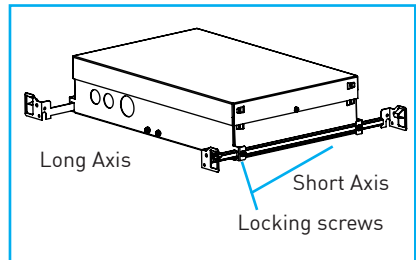

Fig.4

## 2.1 MOUNT HOUSING

**Note:** The applique must be installed after sheetrock and before the mudding process. Plan and secure accordingly to maintain construction schedules.

### General Housing Mounting Notes:

Recessed downlight housings installed in accessible and non-accessible ceilings shall be supported from the structural members of the building.

Determine specified fixture location. With hanger bars properly affixed to housing (see Section D-1.2), attach hanger bars to selected framing member.

### Wood or Metal Studs:

Position reference tab of hanger bar foot to underside of stud (*Fig.5&6*). If wood, use integral nailing tab and suitable customer-supplied nail or screw to secure.

**Note:** Must use two nails or screws at each of four hanger bar feet.

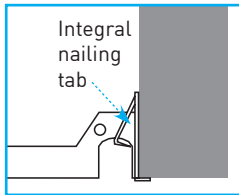

Fig.5

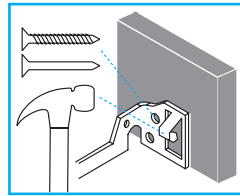

Fig.6

**Important:** Square fixture installations require final alignment. Utilize string line or laser line to obtain uniform or desired alignment between multiple fixtures or in relation to parallel planes.

Verify correct housing aperture position using laser or string line, referencing edges of housing (*Fig.7*), and lock rotating collars once aligned. Tighten hanger bar locking screw to set lateral movement, and ensure all mounting screws are securely tightened (see Section D-1 and D-2).

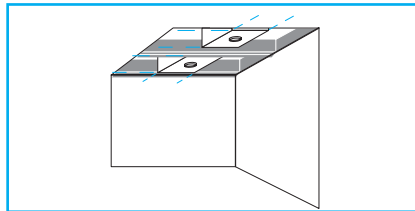

Fig.7

## 2.2 WIRE HOUSING

**Note:** Consult Safety Instructions in Section B prior to commencing wiring or servicing.

### Wiring Installation Process:

Access wiring compartment by loosening the access panel screws and lifting the panel up (Fig.8).

**Note:** Removal of driver is not required.

**Quick connectors (Fig.9)** provided for line / mains voltage connection: black (hot), white (common) and green (ground).

**Note:** For Low Voltage Systems (LVS / UL2108), splice compartment / power supply assembly provides two (2) wires for connection to DC low voltage: Red (+) and Black (-)

**Note:** Consult diagrams on Page 16, wiring housing in accordance with the applicable driver type and proper selection of control voltage wires. Supplied internal wiring is 18-gauge with 600V-rated insulation.

Feed structured building wires through appropriate fitting contained within knockout, secure to corresponding connector (Fig.9) and tighten customer-supplied strain relief.

**Note: 14" (356mm) minimum customer-furnished feed wires** must be supplied within splice compartment to accommodate future servicing. Ensure wires are firmly secured and not tangled prior to moving to the next step.

Push all wires into splice compartment and reinstall splice compartment access panel, ensuring that no wires are pinched by cover.

**Important:** Confirm that housing is still in the preferred position.

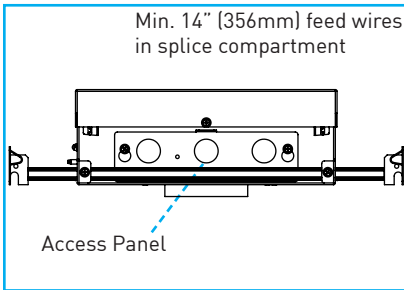

Fig.8

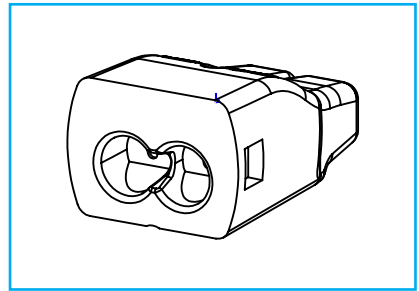

Fig.9

### 2.3 REMOTE POWER SUPPLY

Must install in accessible location. Do not install in environments where ambient temperatures exceed 35°C [95°F]. Determine preferred mounting location, verifying remote power supply enclosure is at least 6" (152mm) from housing and falls within allowable wire capacity distance from selected power supply (Ref. Page 16).

Run suitably sized two-conductor wire between remote driver and fixture location, following installation guidelines for terminating at fixture, as applies.

**Note:** Secondary wiring is polarized (+ / -) and must be terminated correctly at both ends for proper operation. It is recommended to use Red (+) and Black (-) wires to avoid confusion. Additionally, a ground wire must not accompany secondary run wires.

**WARNING:** Failure to use the appropriate gauge wire for the run length required and to ensure proper polarity is observed will cause damage to the unit and void the warranty. Consult wiring diagrams on Page 16, in accordance with the applicable driver.

Access splice compartment by removing retaining screws, then tilting cover slightly back and away from base (Fig. 10). Mount power supply back plate assembly to suitable substrate using customer supplied screws (Fig. 11).

Insert line / mains and control voltage wiring / conduit into line side of splice compartment and secondary voltage wiring / conduit into secondary side of splice compartment utilizing appropriate strain relief or connector (Fig. 12).

Join structured building wires to corresponding driver wires with suitable customer supplied wire connecting device, ensuring proper polarity is observed with secondary wires.

Push all wires and wire connections into splice compartment and reinstall splice compartment cover by aligning tab and slot, ensuring no wires are pinched by cover. Install retaining screws (Fig. 12).

**UL 2108 APPLICATIONS:** Reference drive current information in "Fig. 13" for customer supplied power in low voltage systems.

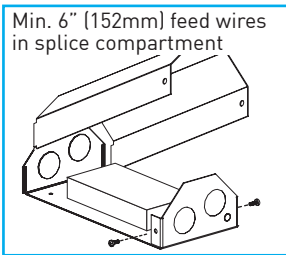

Fig. 10

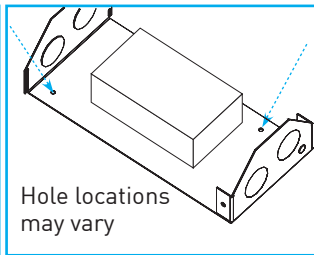

Fig. 11

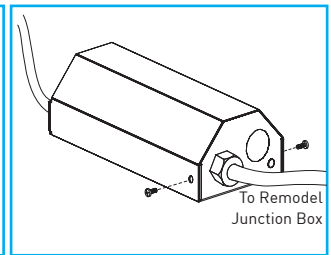

Fig. 12

**Drive Current Information:**

	80S/90S/95S		
	06C	11C	15C
Min. Vf	30.5	30.5	30.5
Max. Vf	39	39	39
Current mA	150	250	350
Wattage W	6	11	15

Fig. 13

## 2.4 CEILING SUBSTRATE & FINISH OUT

### CEILING THICKNESS AND CUT-OUTS

Compatible with 0.50" (13mm) to 1.50" (39mm) ceilings. Correct size and quality of hole is critical, which is different between fixtures with integral and remote power supplies. Double check respective sizes below prior to making ceiling cut-outs.

#### IC & NON-IC HOUSING CUT-OUTS

**3.125" (79mm)** diameter cut-out. Housing

#### REMODEL FIXTURE CUT-OUTS

**6.63" (168mm)** diameter cut-out. Housing is round for both round and square apertures.

Fig. 14

## 2.5 GYPSUM BOARD

Install drywall in typical fashion. Oversized hole cut-outs must be filled in with mud or plaster, utilizing appropriate tape in accordance with industry standards.

**Note:** For trimless drywall installations, see Sections D-1, D-3.1, and F. Trim adaptor with attached appliqué must be installed prior to mudding or finishing of ceiling. Failure to follow these instructions will lead to failed expectations and added expense. Sand, prime, and apply finish coat to ceiling.

## 2.6 WOOD CEILING

Product not intended or advised for wood ceiling installations aside from Trimless Wood applications, see Sections D-1 and D-5

## 2.7 T-GRID LAY-IN TILE CEILING

Product not intended or advised for T-Grid installation applications.

### 3.1 APPLIQUE INSTALLATION

Once housing has been installed with initial alignment completed and proper ceiling cut-out has been made (Fig. 14), carefully raise appliqué assembly into ceiling and attach using collar and gypsum screws, referencing "Fig. 15" for correct collar screw length. Ensure all mounting screws are securely tightened, alternating tightening order to ensure flush installation. **DO NOT OVERTIGHTEN.**

**Important:** Use factory-provided #6 screw size closest to ceiling depth. Gypsum screws are customer-provided and must be no longer than ceiling depth.

**Important:** 1" Round and Square pinhole trimless baffles (1RP/1SP) feature additional locking screws. Tighten using 0.050" allen key prior to plug installation (Fig. 15).

**Important:** Square appliques require alignment. Use string line or laser level to obtain uniform or desired alignment between multiple fixtures or adjacent wall planes. (Fig. 16).

After fixture is secured, ensure baffle is removed and install plaster plug. Apply tape over finger pull to protect optic and LED. Do not remove plug until all plaster and paint work is complete.

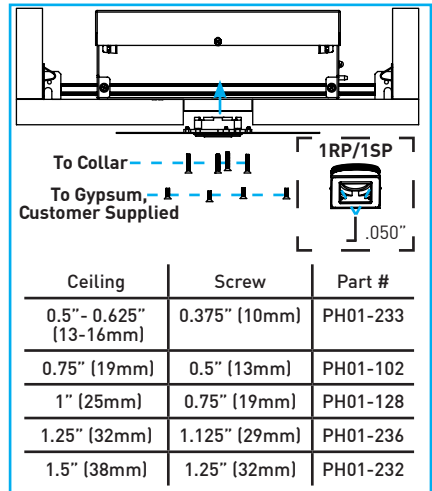

Fig. 15

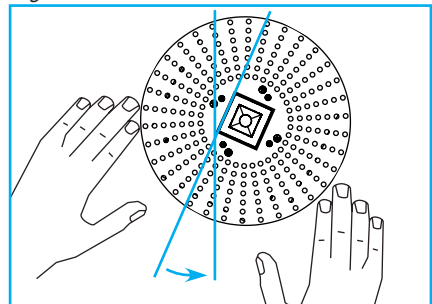

Fig. 16

### 3.2 LED INSTALLATION (HOUSING-BASED)

#### FOR TRIMLESS MILLWORK APPLICATIONS, STOP AND ADVANCE TO SECTION D-4 FOR PROCEDURE PRIOR TO LED INSTALLATION

These instructions pertain to LED installation for integral driver housing-based fixtures only; remodel fixtures will have LED modules installed before shipment.

**WARNING:** Do not energize housing before removing disposable foam plug.

Insert LED tool into assembly, rotating clockwise to first engage snap collar tabs, then further rotating clockwise to engage LED module with heat sink retention tabs. (Fig. 17)

**Note** LED module will not rotate further, nor move loosely, once properly engaged with retention tabs (Fig. 18).

**WARNING:** Do not overtighten.

Remove LED installation tool once module is properly engaged. Using hands, carefully press LED assembly into either applique collar (trimless drywall installations) or millwork collar (trimless millwork applications) until snap collar tabs engage (Fig. 19), taking caution not to mar surface of LED when pressing.

**Note:** Reinstall foam plug to accommodate rough-in construction, prior to final baffle installation

#### ADVANCE TO SECTION F FOR TRIMLESS DRYWALL INSTALLATION

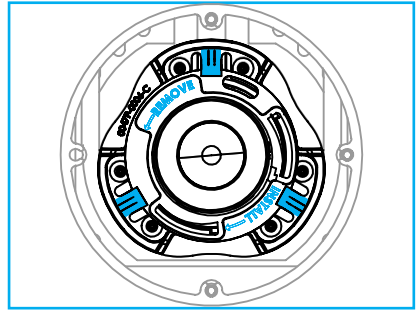

Fig. 17

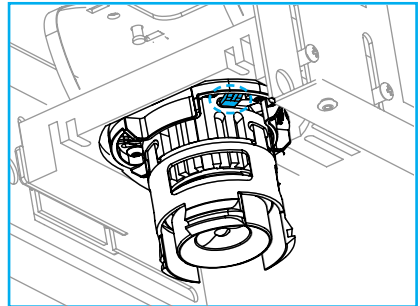

Fig. 18

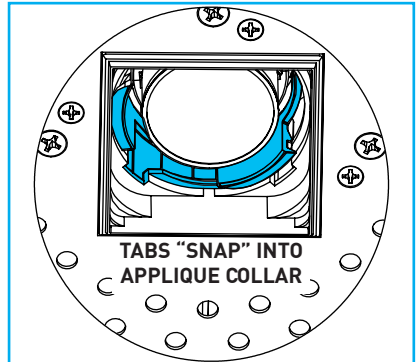

Fig. 19

#### 4. TRIMLESS MILLWORK

**WARNING:** LED IS INSTALLED AS FINAL STEP. DO NOT INSTALL PRIOR TO MILLWORK PROCEDURE OUTLINED IN THIS SECTION

Determine the required spacer stack and counterbore depth based upon the finished wood layer thickness (Fig.20).

Finished Layer	Counterbore (X)	Spacer Stack	Thin Spacer	Thick Spacer
1" (25mm)	3/4" (19mm)	11/16" (17mm)	1 (1/16")	5 (5/8")
7/8" (22mm)	5/8" (16mm)	9/16" (14mm)	1 (1/16")	4 (1/2")
3/4" (19mm)	1/2" (13mm)	7/16" (11mm)	1 (1/16")	3 (3/8")
5/8" (16mm)	3/8" (10mm)	5/16" (8mm)	1 (1/16")	2 (1/4")
1/2" (13mm)	1/4" (6mm)	3/16" (5mm)	1 (1/16")	1 (1/8")

Fig.20

Install spacers onto the trim as shown in "Fig.21". The combined thickness of the spacers and flange must be equal to the counterbore depth.

Raise the trim assembly into the housing aperture and rotate it counter-clockwise onto the trim screws. Hand-tighten trim screws using a 5/64" hex wrench, not exceeding 5 in-lbs (0.565 N-m), ensuring trim flange seats uniformly flush with ceiling backing (Fig.22).

**WARNING:** Failure to install disposable foam plug may result in fire.

Install the round or square disposable foam plug into the trim aperture to prevent contamination of the housing (Fig.24).

**WARNING:** Do not energize housing before removing disposable foam plug.

**Note:** Backing required for remodel installations, reference "Fig. 23"

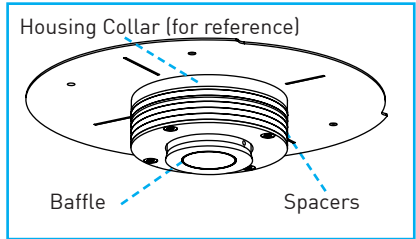

Fig.21

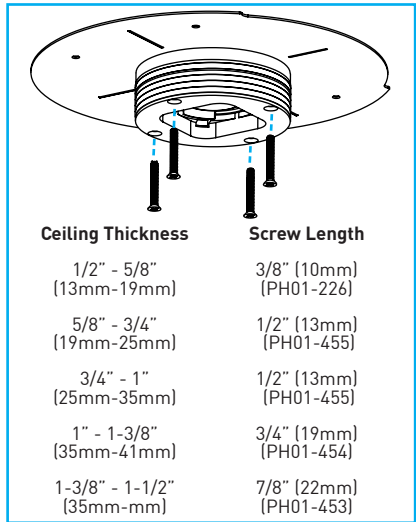

Fig.22

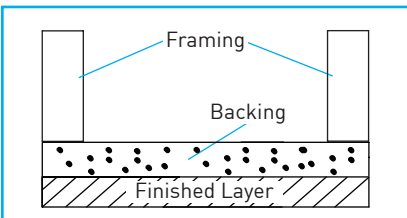

Fig.23

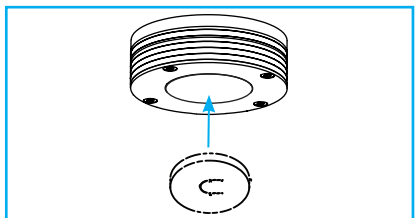

Fig.24

**Note:** Requires trim / compact router with a flush trim profile bit set to 1/4" (6mm) depth.

Locate and mark the center-line of the trim aperture on the finished wood layer. Drill a 5/8" (16mm) pilot hole to accommodate router bit (*Fig.25*).

**Important:** Counterbore depth must be 1/4" less than the total thickness to ensure proper baffle fitment.

Counterbore a space larger than the trim using the predetermined depth in *Fig.20* (*Fig.26*).

**Note:** Factory does not recommend counterboring the entire width of wood.

Counterbore must be larger than the trim footprint to ensure finished wood layer can be installed (*Fig.27*).

Install finished substrate, ensuring the centerlines of the housing and substrate are concentric (*Fig.28*).

Utilizing a trim/compact router with a flush trim profile bit set to a 1/4" (6mm) depth, begin router cut in the pilot hole and move outwards towards the trim edge. Using the inside of the trim as a guide work around the inside of the trim to complete cutout (*Fig.29*).

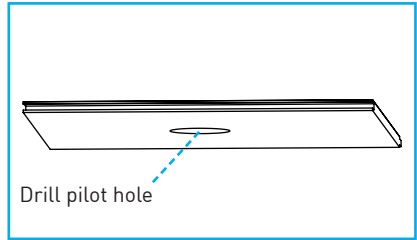

*Fig.25*

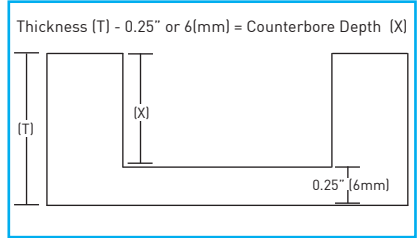

*Fig.26*

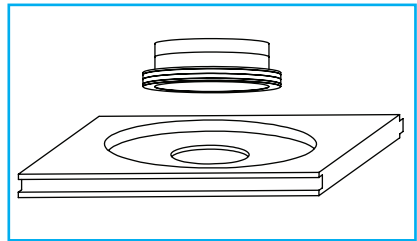

*Fig.27*

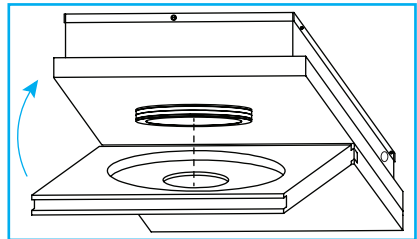

*Fig.28*

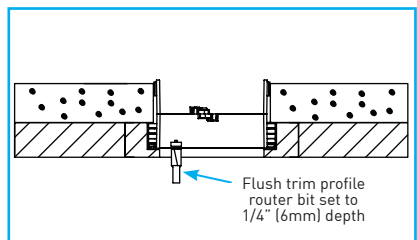

*Fig.29*

**Note:** Ensure tools used to square and clean cutout are sharp and clean.

On square installations, use a sharp utility knife to square the corners of the cutout to ensure proper baffle fitment (Fig.30).

On all installations use a utility knife fine file, or sharp chisel to deburr any rough edges of the cutout to ensure proper baffle fitment (Fig.31).

Once all woodwork has been completed, remove disposable foam plug (Fig.32).

**WARNING:** Do not energize housing before removing disposable foam plug.

**Note:** RETURN TO SECTION D-3.2 FOR LED MODULE INSTALLATION (Fig.33)

Once LED is installed, finish by installing baffle, pushing up until flush with finished ceiling plane (Fig.34).

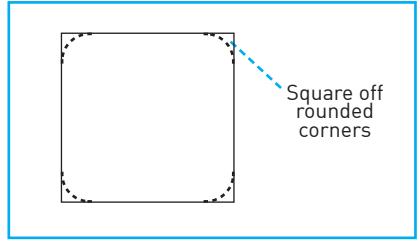

Fig.30

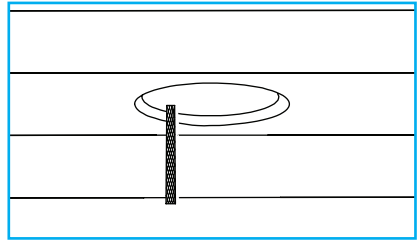

Fig.31

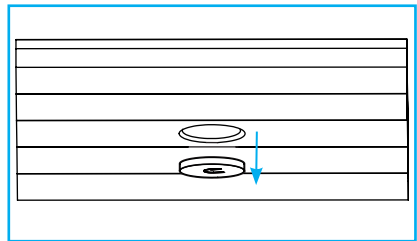

Fig.32

### D-3.2. LED INSTALLATION

Fig.33

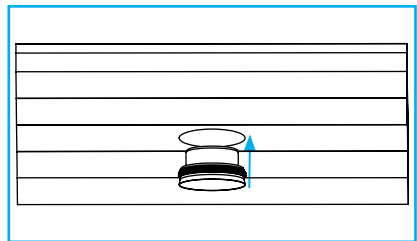

Fig.34

## E. REMODEL APPLICATION

### 1 REMODEL HOUSING INSTALLATION - GENERAL WIRING NOTES

These instructions are for remodel applications only. For housings, see Section D-2.2. During rough-in stage of construction, identify approximate fixture locations. Install appropriate conduit and wiring to each predetermined fixture location, in accordance with NEC and local code requirements, ensuring that adequate slack is provided for making connections to fixture from below finished ceiling plane.

Install finished ceiling (see Section "D-2.4 CEILING SUBSTRATE AND FINISH OUT"). For trimless and zero-sightline mud-in applications, see Section D-3.1 and Section F.

Determine center point of trim location, boring clean and precise cut-out. Be cautious to avoid cutting or nicking wires above (see Section "C. WIRING").

Locate and guide structured wiring / conduit down and through ceiling cutout "Fig.35".

### 2. WIRE REMOTE REMODEL POWER SUPPLY

**Note:** Reference Section D-2.3 for remote remodel power supply installation.

Push all wires and wire connections into remodel junction box, and reinstall junction box cover by aligning tab and slot, ensuring no wires are pinched by cover. Install retaining screw(s).

Make appropriate ceiling cutout, followed by inserting remodel mounting plate (Fig.35). Carefully insert remodel junction box up through cut-out to rest atop the ceiling, taking care not to damage ceiling plane or cutout shown in "Fig.36". Make secondary LED wiring connections in remodel splice compartment from remote power supply, utilizing instructions in Section D-2.3 (Fig. 36)

**Note:** Ensure remodel mounting plate flanges face upward at time of ceiling insertion.

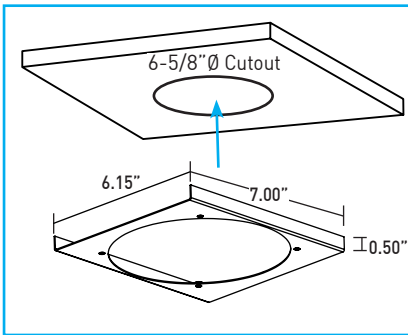

Fig.35

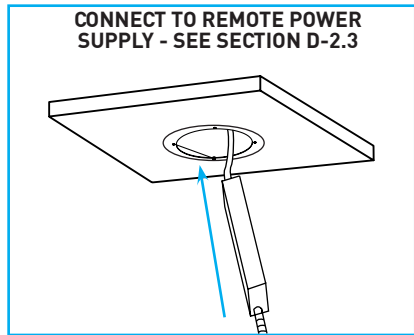

Fig.36

### 3. REMODEL HOUSING AND APPLIQUE INSTALLATION

Ensure ceiling is finished before beginning fitting installation.

Once steps have been completed from Section E-2, insert remodel housing assembly with applique attached into ceiling cutout, aligning mounting screws with respective holes on remodel mounting plate. Ensure applique sits flush to ceiling, avoiding overtightening on mounting screws. *(Fig.37)*

Attach LED wiring to the respective connector end.

**Important:** Use factory-provided #6 screw size closest to ceiling depth. Alternate tightening screws to ensure mounting plate remains flush as applique screws are tightened. **DO NOT OVERTIGHTEN.**

**Important:** Square appliques require alignment. Use string line or laser level to obtain uniform or desired alignment between multiple fixtures or adjacent wall planes. Hand-tighten retaining screws when complete *(Fig.38)*.

**Note:** Fixture functionality test is advised prior to mud-in *(Section F)*.

After fixture is secured, ensure plaster plug is installed *"Fig.39"*. Apply tape over finger pull to protect optic and LED. Do not remove plug until all plaster and paint work is complete.

**WARNING:** Do not energize housing with plaster plug installed.

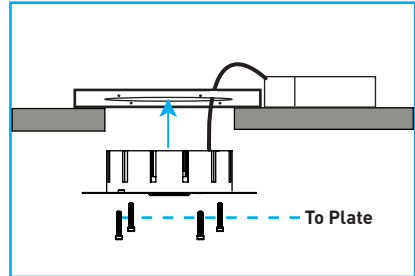

*Fig.37*

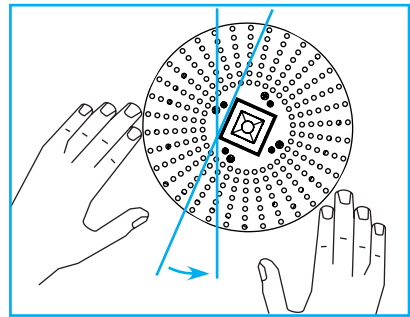

*Fig.38*

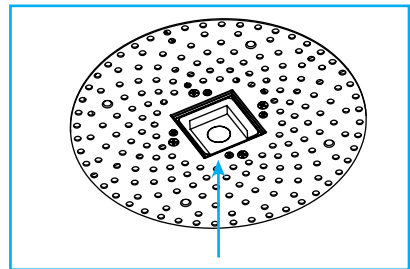

*Fig.39*

## F. TRIMLESS DRYWALL - ALL APPLICATIONS

**Note:** 0.5" and 1.0" trimless baffles and respective plugs must be installed prior to mud-in. (Fig.40) Baffle profiles after mud-in provided for reference in "Fig. 44".

Use floating knife to apply first pass of drywall compound from beyond outer edge of appliqué to inner edge of appliqué / plaster stop. Float out as far as necessary to hide perforated appliqué and allow first pass of joint compound to dry (Fig.41).

Apply second coat of drywall compound level with screed edge, feathering compound as you move away from appliqué to give appearance of a perfectly flat ceiling (Fig.42). Allow drywall compound to dry fully and cure.

Gently use block sanding screen to sand surface (Fig.43) until desired level of smoothness is achieved.

**WARNING:** An unsatisfactory installation will occur if drywall compound is not sufficiently sanded and the flange / plaster stop is at all receded into the ceiling plane.

Once cured, the ceiling may be painted. After paint is dry, remove plaster plug.

**Important:** Apply pressure to baffle when removing mud plug to avoid inadvertent drywall break.

Check for any drywall compound or paint that may have seeped beneath plug and carefully scrape if necessary.

**Important:** Any foreign material left in or on recessed appliqué surface may prevent proper baffle installation and satisfactory trimless appearance.

As applicable, raise baffle with attached lens / film into trim aperture, pushing baffle up until flush with finished ceiling plane.

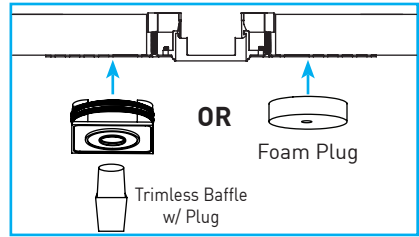

Fig.40

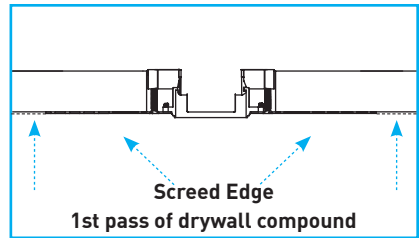

Fig.41

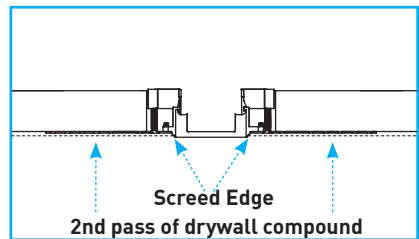

Fig.42

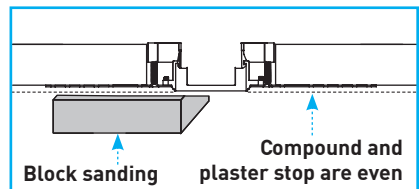
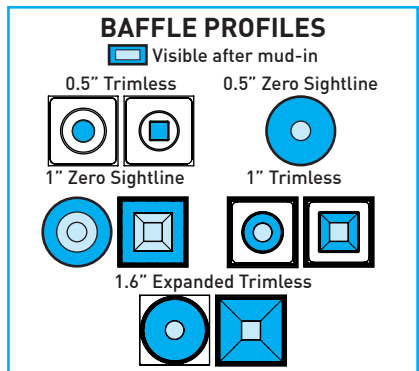

Fig.43



13 Fig.44

## G. SERVICING FIXTURE

**Important:** Before servicing or maintaining fixture, disconnect electrical power at main switch or circuit breaker. Additionally, review notes in Sections A and B and refer to figures in main installation instructions when necessary.

### 1. EXCHANGING OPTIC / EFFECTS DEVICES

- Using baffle removal tool, carefully place edge of tool on inner most aperture rim and gently pull down until baffle is released from housing. **(Fig.45)**
- To change optic, carefully grab and twist counter-clockwise to remove and clockwise to secure. Ensure that both feet of optic properly engage LED base.
- Removal of LED module (Section G-2) is encouraged for ease of optic re-installation.
- Lens is not serviceable on wet rated baffle assemblies; entire baffle assembly must be replaced by first removing existing baffle, outlined in step A.
- Reinsert baffle to locked position by pushing up into trim aperture.

**Note:** Trimless 0.5" and 1" apertures require a 1.7" square ceiling break to service baffle, optic, LED, and driver **(Fig.46)**.

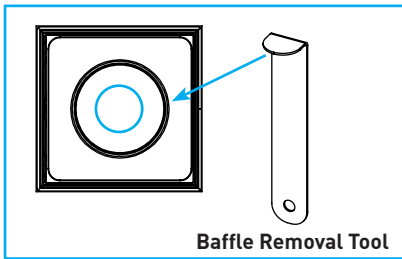

Fig.45

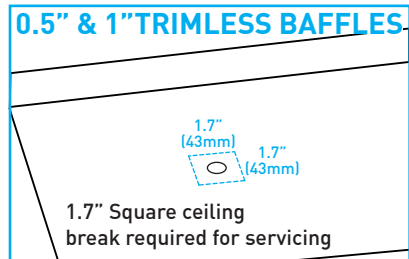

Fig.46

### 2. REPLACING LED ASSEMBLY

- Remove LED assembly:
  - Remove baffle using steps outlined above in Section G-1.
  - Remove optic from LED assembly by twisting counter-clockwise.
- Housing Based:** Attach LED installation tool by first inserting and twisting counter-clockwise to engage tool with LED module, then counter clockwise again to **REMOVE** module from housing. Carefully pull down to completely remove LED module. **(Fig.47)**
- Remodel:** Using a 1/16" allen key, loosen (**do not remove**) LED screws, rotating LED module counter-clockwise to remove from remodel housing. **(Fig.48)**
- Release LED assembly from wiring harness, separating male / female connectors by pulling apart.
- Replace with new OEM LED assembly sourced through Lucifer Lighting, reversing order of preceding steps positioning LED in same orientation, referencing steps in Section D-3.2 as needed.
- Reinstall optic and baffle.

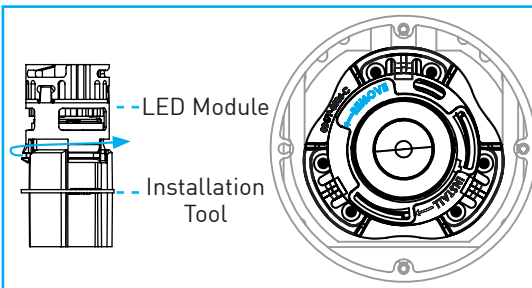

Fig.47

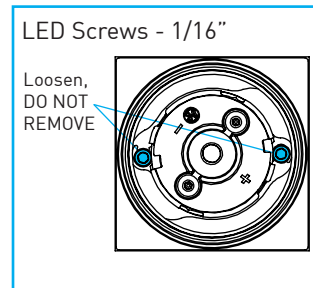

Fig.48

### 3. DRIVER REPLACEMENT

- A. Remove baffle by inserting baffle removal tool referenced in Section G-1 and carefully prying down (*Fig.45*). Remove optic from LED module by twisting counter clockwise.
- B. Remove LED module using steps outlined in Section G-2.
- C. Gently push assembly along heat sink rail, away from driver assembly, to provide sufficient clearance.
- D. Release driver wiring from push-in connectors to LED assembly.
- E. Carefully pull on driver wiring harness to release the driver from the spring tab. Remove driver through housing aperture. (*Fig.49*).
- F. Replace with OEM driver sourced through Lucifer Lighting referencing the wiring instructions in Section D-2.2. Reverse preceding steps to reinstall driver.
- G. Reinstall optic and baffle.

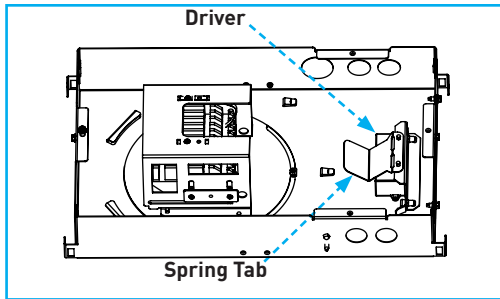
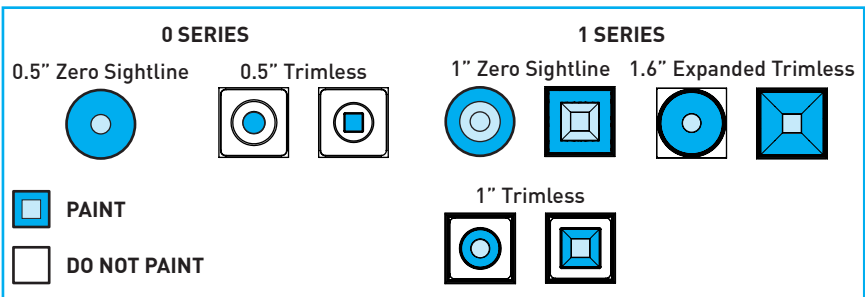

Fig.49

### 4. FIELD PAINTING OF TRIM

Though we strongly recommend custom paint be applied by factory during manufacturing, trim and baffle may be field painted without impacting factory mechanical warranty using following guidelines:

- Select paint suitable for application and location of trim, recognizing that Lucifer Lighting Company fixtures are tested not to exceed temperatures of 90° Celsius. Typical operating temperature of faceplate is 46° Celsius nominal.
- Trim plate surface must be properly prepped in accordance with paint manufacturer's instructions. Paint supplied and furnished by customer.
- Apply paint to exterior baffle and interior of baffle only, do not apply paint to lens. Minimal tolerance exists between baffle and flange. Excess paint buildup may interfere with baffle installation.



## H. DRIVER WIRING DETAIL

### GENERAL WIRING NOTES

1. Consult approved dimmer list to ensure compatibility.
2. Install in accordance with manufacturer's dimmer installation guidelines.
3. Secondary and 0-10V connections are polarity sensitive.

### WIRING DIAGRAM FOR LINE DIMMING

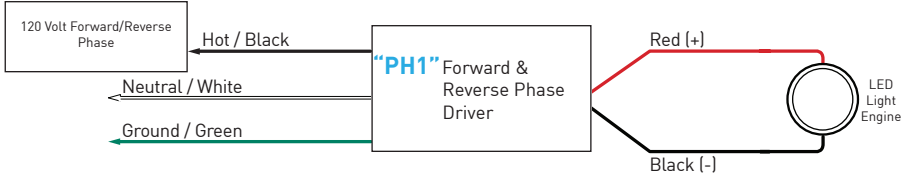

### WIRING DIAGRAM FOR ANALOG CONTROL

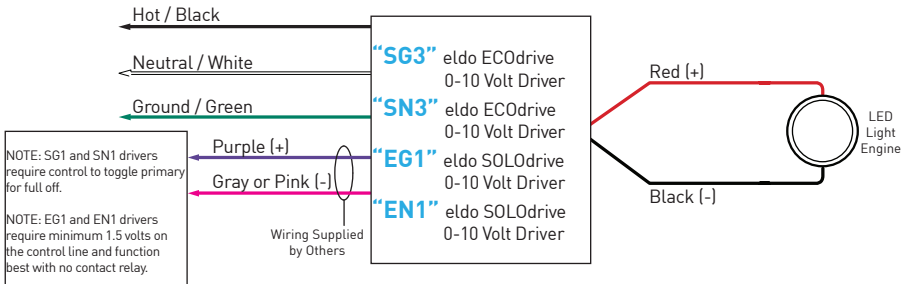

### WIRING DIAGRAM FOR ECOSYSTEM AND DIGITAL CONTROL

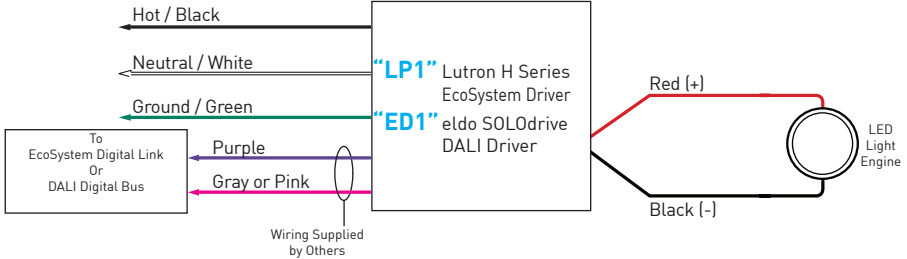

### REMOTE DRIVER WIRING DISTANCE

#### Lutron Drivers: "LP1"

AWG Value	18	16	14	12
Distance (ft)	15	25	40	60
Distance (m)	4.5	7.5	12	18

#### eldoLED Drivers: "ED1", "SG3", "SN3", "EG1", "EN1"

AWG Value	20	18	16
Distance (ft)	46	72	118
Distance (m)	14	22	36

## WIRING DIAGRAM FOR STATIC WHITE / WARM DIM DMX CONTROL

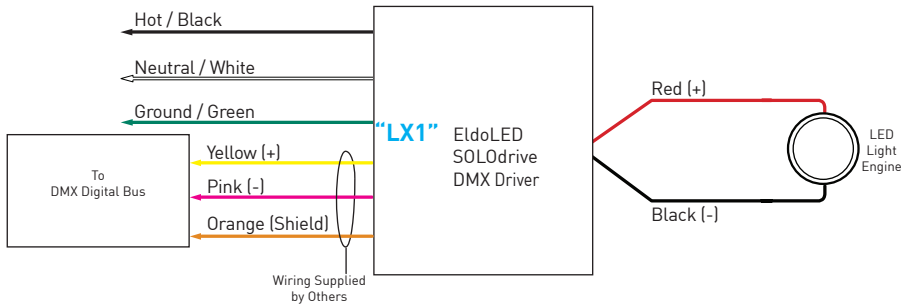

### DMX DIMMING INFORMATION

- Fixtures do not ship pre-addressed; fixture addressing is completed by the installer or a commissioning contractor via RDM.
- All fixtures are RDM compatible.
- DMX Channel Count:  
 Static White / Warm Dim: 1  
 Tunable White: 2; Channel 1 Warm and Channel 2 Cool
- DMX run termination provided by others.
- DMX Connection Type: Pigtail
- DMX Color Scheme:  
 DMX+: Yellow  
 DMX-: Pink  
 DMX Shield: Orange
- Installation may require shielded cable if EMI is present.
- Fixture Default Mode: FULL ON
- Fixture Fail Mode: ON 10% DIMMED

Please consult website for full warranty terms and conditions:

[www.luciferlighting.com/warranty](http://www.luciferlighting.com/warranty)

[05272026]

3750 North PanAm Expressway  
 San Antonio, TX 78219 USA  
 [PH] +1 210 227 7329  
 [FAX] +1 210 227 4967  
[www.luciferlighting.com](http://www.luciferlighting.com)

**LUCIFER**®  
 LIGHTING COMPANY

©2026 Lucifer Lighting Company  
 As part of its policy of continuous research and product development, the Company reserves the right to change or withdraw specifications without prior notice.