

# FRAXION® 4 SLIM / HIGH FLUX

## RECESSED LED DOWNLIGHT HOUSINGS

### INSTALLATION

Before beginning any DOWNLIGHT installation, disconnect electrical power at main switch or circuit breaker.

#### A. CAUTION

To reduce the risk of fire, electric shock, and potential damage to recessed housing assembly when electrical power is re-connected, DO NOT ATTEMPT to CONNECT the following on branch circuit serving recessed downlight assembly:

- Motors
- Power tools
- Extension cords
- Appliances or similar electronics

Housings to be mounted in ceiling / plenum conditions *where ambient temperatures do not exceed 40°C unless otherwise noted as 35°C on specification sheets.*

Ensure AC input voltage is protected against surges & load shifts prior to power supply input.

#### B. SAFETY INSTRUCTIONS

1. Read installation instructions completely before attempting installation.
2. Failure to follow instructions may result in improper installation and void warranty.
3. Contact Lucifer Lighting Company with any questions or concerns before beginning any installation.
4. Ensure qualified electrician will perform all electrical procedures.
5. Disconnect electrical power circuit before attempting to install recessed downlight housing or trim, or if adding to or changing configuration of downlight housing or trim assembly.

6. Install/mount recessed downlight housing on structurally sound surface.
7. Recessed downlight housings must be installed in dry or damp locations only.
8. **IC housing allows:**  
**Direct contact with** polycell spray-in foam insulation having max R-Value of 60 allowed on all sides and top of housing.
9. **Non-IC housing requires:**  
**Minimum 1/2" (13mm)** setback from combustible materials on all sides and top of housing.  
**Minimum 3" (76mm)** setback from insulation material having max R-value of 30 on all sides and top of housing.  
**Minimum 6" (152mm)** from polycell spray-in foam insulation having max R-Value of 60 on all sides and top of housing.
10. **Consult factory for spacing requirements for any installations exceeding R-Value of 60.**

**LUCIFER**  
LIGHTING COMPANY

## C. HOUSING INSTALLATION

### 1. KEY HOUSING COMPONENTS

**Note:** Housing aperture is equipped with a disposable foam plug to minimize dust/paint invasion. Remove after final finish is applied to ceiling.

**WARNING:** Do not energize housing with foam installed.

Become familiar with housing and hanger bar assemblies.

Cover plate "Fig.1" provides access to wiring connections prior to installation of ceiling substrate and is retained with screws.

**Note:** Housing lid is not removable in the field.

Housings outfitted with fixed-depth collar, preset to 0.46" (12mm) for round and square fixtures; deep regress housings feature 0.50" (12.5mm) collar. Collar for square fixtures can be rotated up to 45° to ensure proper alignment. Secure collar to prevent rotation using set screw on bottom of housing "Fig.2".

### 2. HANGER BAR ASSEMBLIES

Hanger bars extend from 14" (356mm) to 24" (610mm) centers and mount to short axis of housing. To install hanger bars on housing, slide mating halves together, joining through mounting bracket on housing sides. Secure position with locking screws "Fig.3".

**Note:** For Deep Regress housings, hanger bars extend below housing "Fig.4".

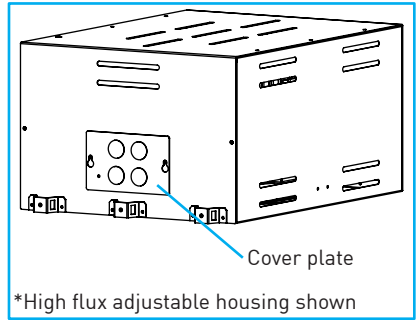

Fig.1

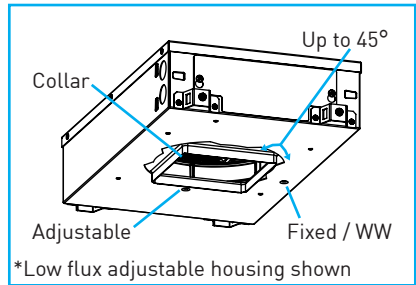

Fig.2

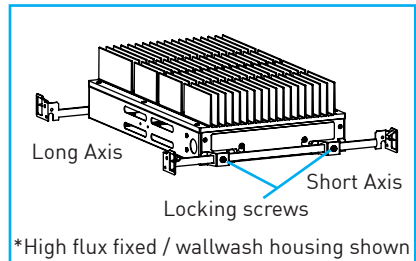

Fig.3

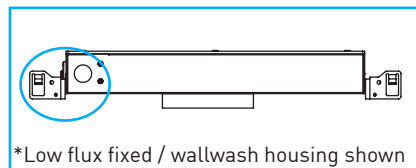

Fig.4

### 3. ADJUSTABLE HEIGHT ACCESSORY

**Note:** Adjustable height bracket ships as an accessory.

Remove mounting accessory hardware screws and lock washers prior to installation "Fig.5". Attach brackets to housing using screws and lock washers and tighten "Fig.6".

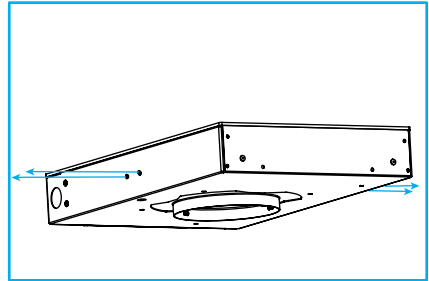

Fig.5

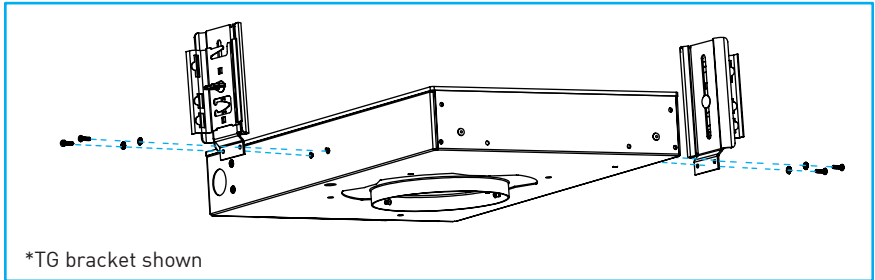

Fig.6

#### **"TG" T-Bar Grid Adjustable Height Bracket:**

Hanger bars extend from 14" (356mm) to 24" (610mm) centers and mount to long axis of housing. To install hanger bars to accessory, slide mating halves together, joining through cutout of mounting bracket "Fig.7". Loosen wing nut on bracket and raise or lower the hanger bars as required, tighten wing nut "Fig.7".

**Note:** Housing height can be adjusted after mounting is completed in step C-4.

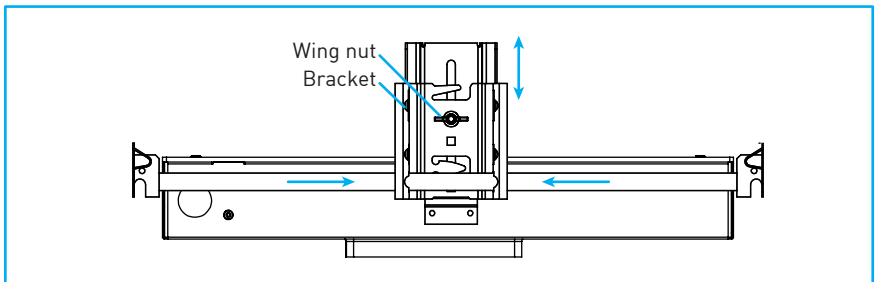

Fig.7

### “BFLY” Butterfly Adjustable Height Bracket:

Requires customer supplied 1/2” conduit, channel, or furring channel for installation. “Fig.8”. Loosen wing nut on bracket and raise or lower the hangar bars as required, tighten wing nut “Fig.8”.

**Note:** Housing height can be adjusted after mounting is completed in step C-4.

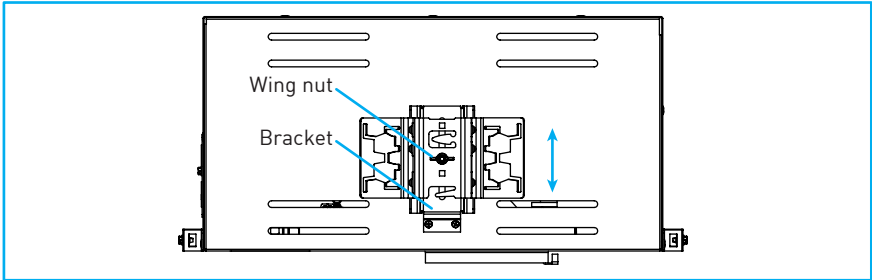

Fig.8

## 4. MOUNT HOUSING

Follow steps to ensure successful installation.

### General Housing Mounting Notes:

Recessed downlight housings installed in accessible and non-accessible ceilings shall be supported from the structural members of the building.

Determine specified fixture location. With hanger bars properly affixed to housing (see Section C-2), secure hanger bars to selected framing member.

### Wallwash Housing:

Housing is shipped with LED module angled away from splice compartment and may be rotated up to 90° “Fig.9”. LED module may also be removed and repositioned.

**To rotate LED module:** Loosen two Phillips screws, rotate LED as shown below and tighten screws “Fig.10”.

**To reposition LED module:** Remove two phillips screws “Fig.10”, rotate LED module and replace screws, tightening uniformly to ensure the module is flat and flush to housing lid.

**WARNING:** Do not overtighten. Never tighten LED screws using a powered screwdriver.

**Note:** The LED module may need to be removed to service power supply.

**Note:** Do not remove disposable foam plug until plaster and paint has dried and baffle is ready to be installed.

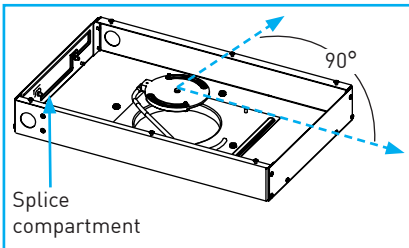

Fig.9

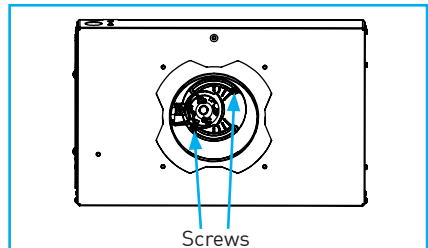

Fig.10

**WARNING:** Do not energize housing before removing disposable plug.

**Wood or Metal Studs:**

Position reference tab of hanger bar foot to underside of stud "Fig.11". If wood stud, use integral nailing tab and suitable customer-supplied nails or screws to secure. If metal stud, use suitable customer-supplied screws "Fig.12".

**Note:** Must use two nails or screws at each of four hanger bar feet.

**T-Bar Frame:**

Slide hanger bar over appropriately supported T-bar frame. Lock in place as required "Fig.13".

**Note:** See Section E for additional instructions regarding installation of ceiling tiles.

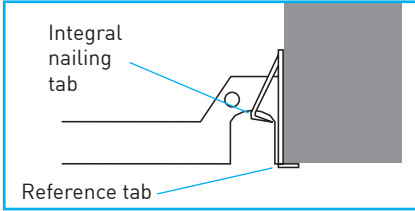

Fig.11

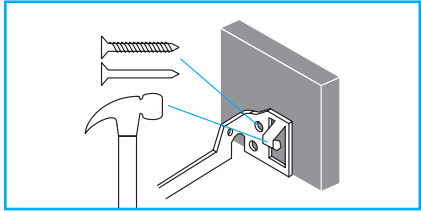

Fig.12

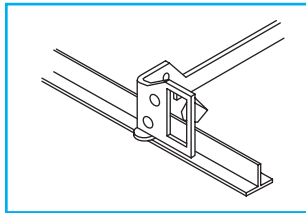

Fig.13

Verify correct housing aperture position using laser or string line, referencing edges of housing "Fig.14".

Tighten hanger bar locking screw to set lateral movement, and ensure all mounting screws are securely tightened (see Section C-2).

**Important:** Collar must not protrude beyond ceiling plane "Fig.15".

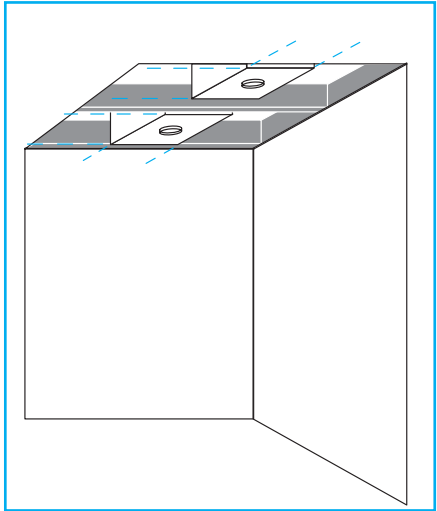

Fig.14

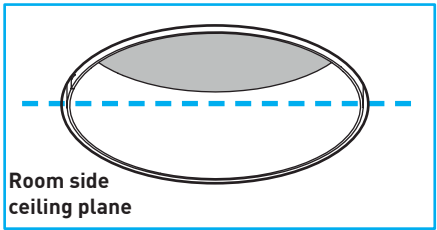

Fig.15

## 5. HIGH FLUX ADJUSTABLE SHIPPING BRACKET

Remove Phillips screw and discard shipping bracket "Fig.16".

**Important:** Shipping bracket must be removed prior to substrate installation.

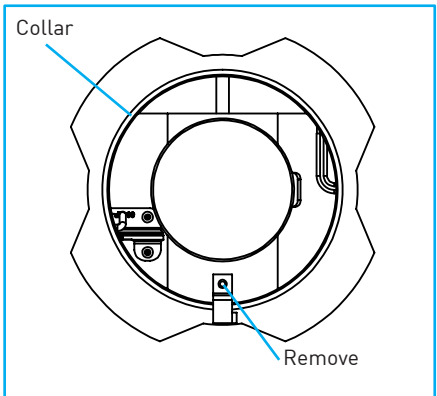

Fig.16

## D. WIRING

### 1. GENERAL WIRING NOTES

**Note:** Consult Safety Instructions in Section B prior to commencing wiring or servicing.

The housing assembly should be installed by a registered electrician and shall comply with National Electric Code (NEC) and local codes and ordinances .

The installer is responsible for furnishing proper electrical equipment and materials for the installations of the housings as intended by these installation instructions.

Install wiring in a manner to permit access to components and splice connections which may require future service. **8" (203mm) minimum customer-furnished feed wires** must be supplied within housing to accommodate future servicing.

Metal conduit shall be used if required by applicable codes. Must use 90°C minimum supply wire only.

No part of the secondary circuit shall be grounded.

For systems that will be dimmed, consult controls manufacturer to verify control compatibility and for proper installation procedures and parameters.

### 2. WIRE HOUSING - UL 1598 INSTALLATIONS ONLY

To gain access to wiring compartment, loosen retaining screws and lift cover plate up and away "Fig.17".

**Note:** Removal of driver is **not** required.

Feed structured building wires through knockout, secure to corresponding connector "Fig.18" and tighten strain relief.

**Quick connectors** provided for line / mains voltage connection: black (hot), white (common) and green (ground) "Fig.18".

**Note:** At least 10" (254mm) of service loop must be provided in the splice compartment for driver servicing.

**Note:** Consult diagrams in Section J, wiring housing in accordance with the applicable driver type and proper selection of control voltage wires. Supplied internal wiring is 18-gauge with 600V-rated insulation.

**Note:** Ensure wires are firmly secured and not tangled prior to moving to the next step.

Push all wires into housing and reinstall cover plate, ensuring that no wires are pinched by cover.

**Important:** Confirm that housing is still in the preferred position.

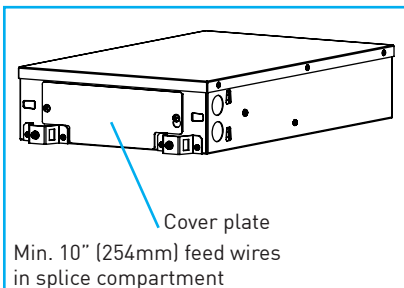

Fig.17

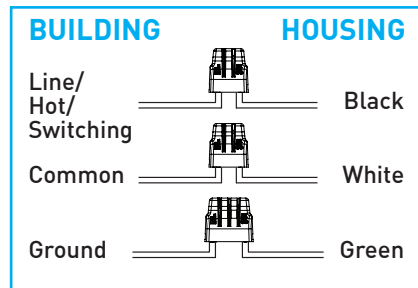

Fig.18

### 3. WIRE REMOTE POWER SUPPLY - UL 1598 INSTALLATIONS ONLY

Determine preferred mounting location, verifying fixture falls within maximum allowable wiring distance *"Fig.19"*.

Run adequately sized two-pair wire between remote driver and housing or remodel fixture location, following installation guidelines for terminating as needed.

**Note:** Secondary wiring is polarized (+/-) and must be terminated correctly at both ends for proper operation. It is recommended to use Red (+) and Black (-) wires to avoid confusion. No part of the secondary circuit shall be grounded.

*Ensure proper polarity is observed as reversed polarity may damage the unit and may void the warranty.*

Access splice compartment by removing retaining screws, then tilting cover slightly back and away from base *"Fig.20"*.

Mount transformer back plate assembly to suitable substrate using customer-supplied screws *"Fig.21"*.

Insert line voltage wiring / conduit into line side of splice compartment and secondary voltage wiring / conduit into secondary side of splice compartment, utilizing appropriate strain relief or connector.

**Note:** Consult wiring diagrams in Section J for applicable driver type.

Join structured building wires to corresponding driver wires with suitable customer-supplied wire connecting device.

Push all wires and wire connections into splice compartment and reinstall splice compartment cover by aligning tab with slot, ensuring no wires are pinched by cover. Install retaining screws.

#### Lutron Drivers: "L23", "LH1", & "LP1"

AWG Value	18	16	14	12
Distance (m)	4.5	7.5	12	18
Distance (ft)	15	25	40	60

#### Philips Drivers: "TR2" & "AN4"

AWG Value	20	18	16	14	12
Distance (m)	14	22	34	55	87
Distance (ft)	45	71	113	180	285

#### eldoLED Drivers: "ED1", "LD1", "LA2", "EA2", "DD1", "DG1" & "DL1"

AWG Value	20	19	18	17	16
Distance (m)	14	18	22	28	36
Distance (ft)	46	59	72	92	118

Fig.19

Min. .8" feed wires in splice compartment

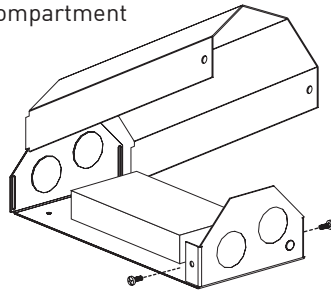

Fig.20

Hole locations may vary

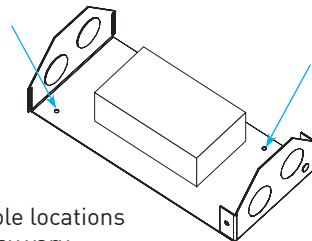

Fig.21



#### 4. WIRE HOUSING - UL2108 INSTALLATIONS ONLY

To gain access to wiring compartment, loosen retaining screws and lift cover plate up and away "Fig.22".

**Note:** Supplied internal wiring is 18-gauge with 600V-rated insulation.

Feed structured building wires through knockout, secure to corresponding connector "Fig.23" and tighten strain relief.

**Quick connectors** provided for low voltage connection: Red (+) and Black (-) "Fig.23".

**Note:** Ensure wires are firmly secured and not tangled prior to moving to the next step.

Push all wires into housing and reinstall cover plate, ensuring that no wires are pinched by cover.

**Note:** Installed housings permit access to components and splice connections. "Customer-supplied feed wires" within splice compartment should be provided in minimum lengths of 10" (254mm) to accommodate future servicing.

**Important:** Confirm that housing is still in the preferred position.

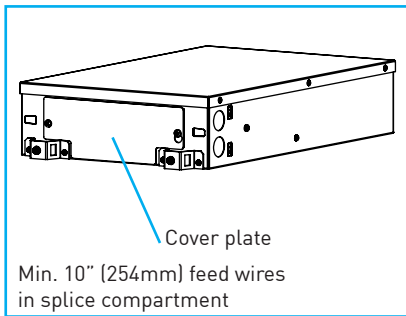

Fig.22

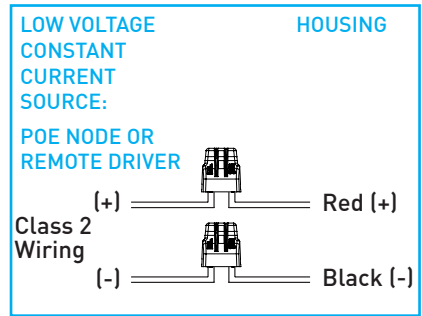





Fig.23

**Drive Current Information:**

	80C						90C					
	12A	16A	23A	30B	36B	58B	10A	14A	19A	26B	30B	50B
Minimum Vf	30.5	30.5	30.5	30.5	30.5	30.5	30.5	30.5	30.5	30.5	30.5	30.5
Maximum Vf	39	39	39	39	39	39	39	39	39	39	39	39
Current mA	250	350	500	700	850	1250	250	350	500	700	850	1250
Wattage W	8.2	11.8	17.4	25.4	31.6	43.6	8.2	11.8	17.4	25.4	31.6	43.6

	97C						90W			90T	
	10A	12A	17A	23B	27B	41B	13A	19E	31F	10B	14B
Minimum Vf	30.5	30.5	30.5	30.5	30.5	30.5	30.5	30.5	30.5	30.5	30.5
Maximum Vf	39	39	39	39	39	39	39	39	39	39	39
Current mA	250	350	500	700	850	1250	350	600	950	350	500
Wattage W	8.2	11.8	17.4	25.4	31.6	14	11.8	20.1	32.4	14	22

**Node Compatibility:**

Manufacturer	Model Number
	NP50-60-C-F-5
	180996-1001 180996-1002 180996-2001 180996-2002
	1 Channel Node, POE-LN2-1U-E 2 Channel Node, POE-LN2-2U-E 4 Channel Node, POE-LN2-4U-E

## E. CEILING SUBSTRATE AND FINISH OUT

### 1. CEILING THICKNESS

Compatible with 0.50" (13mm) to 1.0" (25mm) ceilings.

### 2. CEILING CUT-OUTS

Factory recommends use of properly sized hole saw for cut-outs. Correct size and quality of hole is critical. Many trims have minimal ceiling overlay of trim flange.

Make proper hole cut-out, referencing measurements from adjacent walls to housing collar / aperture centerline.

#### IC & NON-IC HOUSINGS CEILING CUT-OUTS

**4.625" (117mm)** dia. for round fixtures

**4.625" (117mm)** for square fixtures

### 3. JA8-2016 TITLE 24 INSTALLATIONS

Once the ceiling is installed, using a caulk suitable for the site conditions and associated materials, apply a bead of caulk between housing collar and ceiling substrate to create an airtight seal, in accordance with CEC instructions and guidelines *"Fig.24"* & *"Fig.25"*.

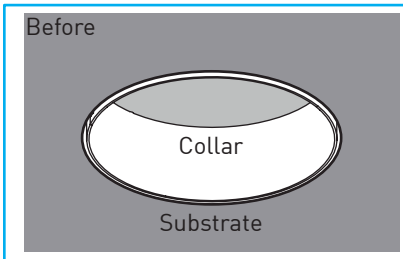

Fig.24

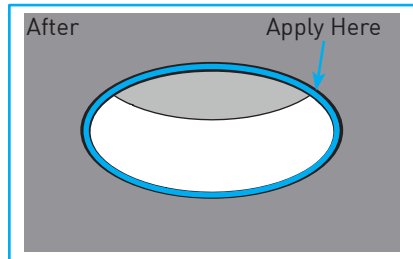

Fig.25

### 4. GYPSUM BOARD

**Important:** Square fixture installations require final alignment. Utilize string line or laser line to obtain uniform or desired alignment between multiple fixtures or in relation to parallel planes.

Install drywall in typical fashion. Oversized hole cut-outs must be filled in with mud or plaster, utilizing appropriate tape in accordance with industry standards, prior to trim installation.

**Note:** For mud-in drywall installations, see Section F-2.

**Important:** If mud-in, appliqué must be installed prior to mudding or finishing of ceiling. Failure to follow these instructions will lead to failed expectations and added expense.

Sand, prime, and apply finish coat to ceiling.

### 5. WOOD CEILING

Install wood in accordance with local and national building codes, employing suitable fire barriers as required. Hole cut-outs should be clean and precise. Sand, stain and apply finish seal coat prior to installing trim.

**Important:** Trimless installations are not compatible with wood ceiling applications.

## 6. T-GRID LAY-IN TILE CEILING

Install tiles in accordance with manufacturer's recommendations. Housings must be fully supported by T-grid or framing structure above and not solely by decorative ceiling tile.

**Note:** See General Housing Mounting Notes in Section C-4.

**Important:** Trimless installations are not compatible with lay-in tile ceiling applications.

## F. TRIM INSTALLATION

Ensure ceiling is finished before beginning trim installation.

Remove disposable foam plug.

### 1. FLANGED

**Important:** Before installing trim in ceiling, ensure that LED module is properly secured in place and the optic is aligned and locked into LED module. Secure optic to LED module by aligning two locking tabs and twisting clockwise "Fig.26".

Raise trim flange into housing collar, making sure that the retaining clamps are pointed inward into aperture. Once seated in housing, begin tightening clamping screws, ensuring clamps swing out and then down to engage top of housing collar lip "Fig.27".

**Important:** For square fixture installations, fixture requires final alignment. Utilize string line or laser level to obtain uniform or desired alignment between multiple fixtures or in relation to parallel planes.

Hand-tighten clamping screws, not exceeding 5 in-lbs (0.565 N-m), ensuring that trim flange seats uniformly flush with finished ceiling plane "Fig.27".

**WARNING:** Do not overtighten. Never tighten clamping screws using a powered screwdriver.

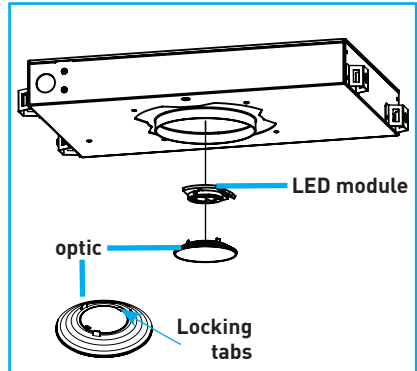

Fig.26

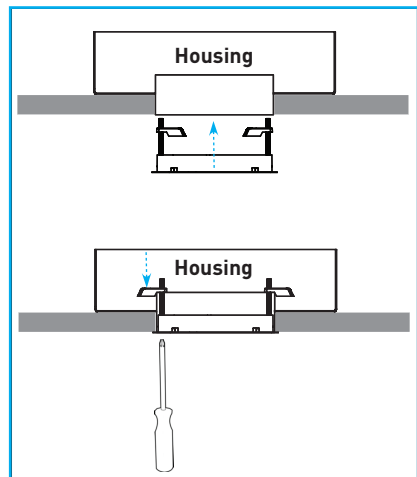

Fig.27

## 2. MUD-IN

**Important:** Appliqué must be installed prior to mudding or finishing of ceiling. Failure to follow these instructions will lead to failed expectations and added expense.

Raise appliqué into housing collar until flush with substrate. Using factory supplied screws, secure appliqué to substrate "Fig.28".

**Important:** For square fixture installations, appliqué requires final alignment. Utilize string line or laser level to obtain uniform or desired alignment between multiple fixtures or in relation to parallel planes.

Hand-tighten screws, ensuring that appliqué seats uniformly flush with finished ceiling plane "Fig.29".

**WARNING:** Do not overtighten. Never tighten screws using a powered screwdriver.

After appliqué is secured, install plaster plug "Fig.29". Apply tape over finger pull to protect optic and LED. Do not remove plug until all plaster and paint work is complete.

Use floating knife to apply first pass of drywall compound and float area up to slightly below edge of appliqué / plaster stop. Float out as far as necessary to hide perforated appliqué and allow first pass of joint compound to dry "Fig.30".

Apply second coat of drywall compound level with screed edge, feathering compound as you move away from appliqué to give appearance of a perfectly flat ceiling "Fig.31". Allow drywall compound to dry fully and cure.

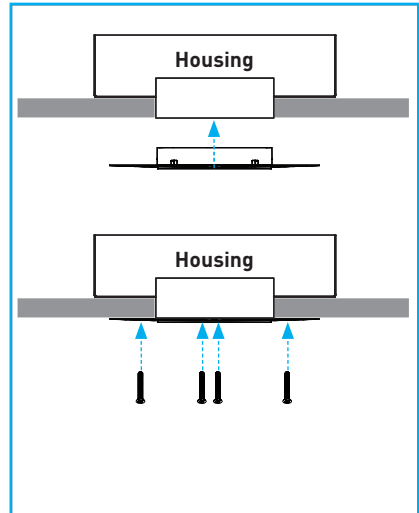

Fig.28

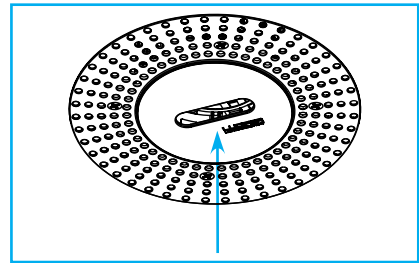

Fig.29

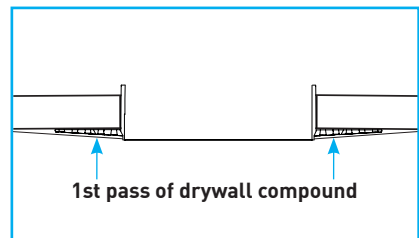

Fig.30

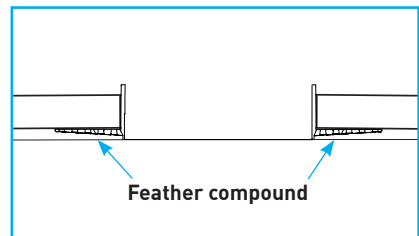

Fig.31

Gently use block sanding screen to sand surface "Fig.32" until desired level of smoothness is achieved.

**WARNING:** An unsatisfactory installation will occur if drywall compound is not sufficiently sanded and the flange / plaster stop is at all receded into the ceiling plane.

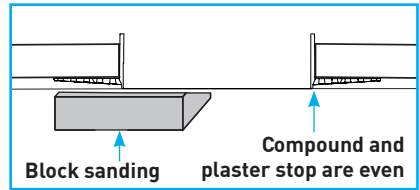

Fig.32

Once cured, the ceiling may be painted. After paint is dry, remove plaster plug. Check for any drywall compound or paint that may have seeped beneath plug and carefully scrape if necessary.

**Important:** Any foreign material left in or on recessed appliqué surface may prevent proper baffle installation and satisfactory trimless appearance.

## G. ADJUSTABLE FIXTURES

### 1. ADJUSTABLE TRIMS

Hot-aimable tilt and rotation adjustment is accessed by removing fixture's baffle, revealing adjustment mechanisms "Fig.33".

Adjustments to fixture tilt and rotation are most effective when made after installing fixture into ceiling.

**Tilt:** Pull on spring pin towards center of housing aperture and rotate down to lock pin in tilting position. Use heat sink handle, or pin bracket on high flux fixtures to adjust angle. Rotate spring pin up and release to reengage locking mechanism "Fig.33".

**Rotation:** Locate thumb screw and loosen by turning counter-clockwise. Grasp heat sink handle to rotate assembly. Turn thumb screw clockwise to secure "Fig.33".

**DO NOT OVER-TIGHTEN.**

**Note:** Fixture may need to be in a tilted position to allow full 365° rotation.

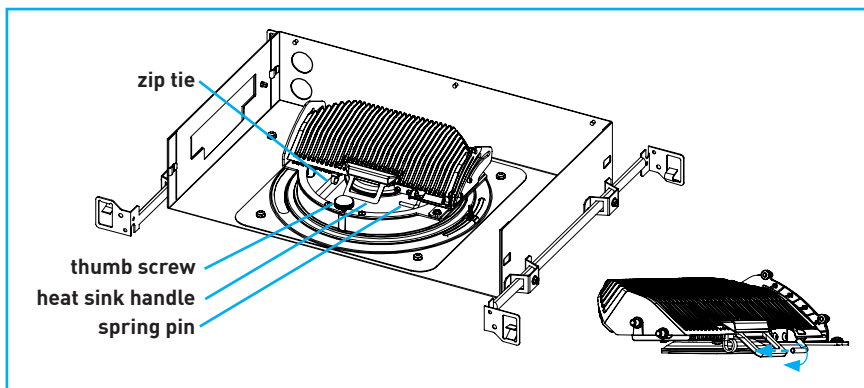

Fig.33

## 2. ADJUSTABLE HCL ASSEMBLY

Allows for Honeycomb Louver and a secondary effects device to tilt and rotate with adjustable fixtures.

Install HCL and specified secondary effects device in retainer, ensuring the HCL is installed first "Fig.34".

With aiming completed and optic installed, raise assembly up and carefully clip onto optic "Fig.35".

**WARNING:** Ensure standard effects device and lens retainer are not installed on baffle prior to installation.

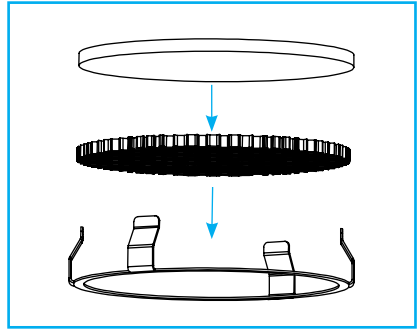

Fig.34

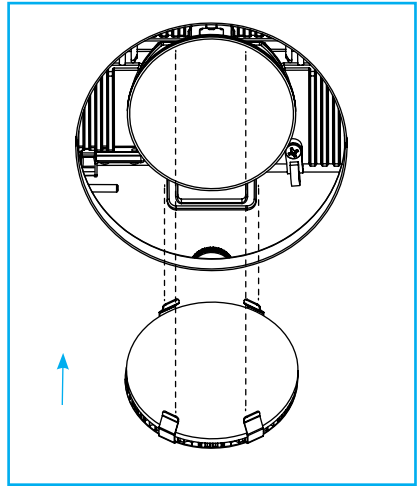

Fig.35

## H. BAFFLE INSTALLATION

### 1. INSTALL BAFFLE

Raise baffle into trim aperture, and push up until baffle locks into place "Fig.36".

**Wallwash Fixtures:** Baffle requires alignment to achieve proper wallwashing. Ensure that the baffle and trim are oriented to direct light perpendicular to the washed wall "Fig.37".

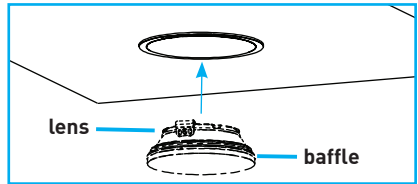

Fig.36

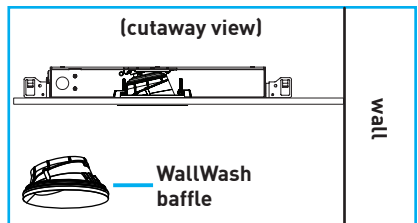

Fig.37

## I. SERVICING FIXTURE

**Important:** Before servicing or maintaining trim or housing, disconnect electrical power at main switch or circuit breaker. Additionally, heed all WARNINGS and CAUTIONS, review the Safety Instructions, and refer to figures in main installation instructions where necessary.

### 1. EXCHANGING OPTIC / EFFECTS DEVICES

A. Remove baffle. Dry location baffles are removed by lifting lens and pulling down on the top of baffle. We location baffles or those with sealed lenses are removed by pulling down on the lens with a suction cup. Wallwash baffles require inserting small flat head screwdriver and carefully prying down as shown in "Fig.38".

B. To change optic, carefully grab and twist counter-clockwise to remove and clockwise to secure. Ensure that both feet of optic properly engage LED base.

C. To change lens / film, remove lens retainer and gasket by loosening and removing screw. Insert preferred lens / film in proper orientation, securing with lens retainer / gasket and replacing and tightening screws "Fig.39".

D. Raise baffle into aperture, and push up until baffle locks into place.

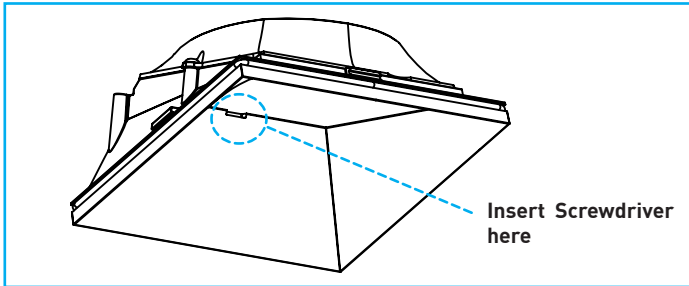

Fig.38

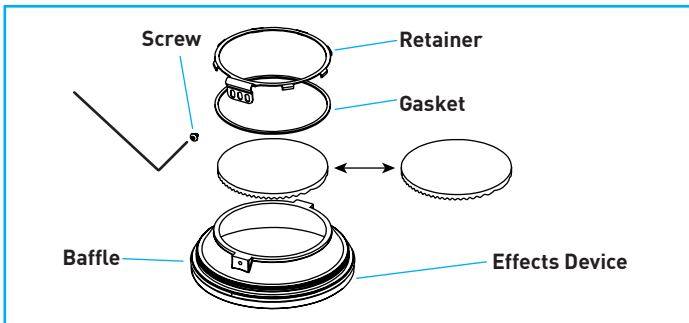

Fig.39



## 2. REPLACING LED ASSEMBLY

- A. Remove baffle. Dry location baffles are removed by lifting lens and pulling down on the top of baffle. Wet location baffles or those with sealed lenses are removed by pulling down on lens with a suction cup. Wallwash baffles require inserting small flat head screwdriver and carefully prying down as shown in *"Fig.38"*.
- B. Remove optic from LED base by twisting counter-clockwise.
- C. Using standard Phillips-head screwdriver, remove 2 LED assembly retaining screws to detach from mounting surface *"Fig.40"*.
- D. Disconnect the LED engine assembly wiring from connectors or driver wiring.
- E. On Non-IC High Flux Adjustable housings only, remove thermal pill from heatsink *"Fig.41"*.
- F. Replace with new OEM LED engine assembly sourced through Lucifer Lighting. Attach LED wiring to the corresponding 2-pin lever-nut connectors, Red to Red (+), Black to Black or Blue (-). Using standard Phillips-head screwdriver, install LED assembly with 2 screws *"Fig.40"*.
- G. For Non-IC High Flux Adjustable housings only, install thermal pill on heatsink *"Fig.41"*.
- H. Ensure that both feet of optic properly engage LED base and twist clockwise to secure.
- I. Raise baffle into aperture, and push up until baffle locks into place.

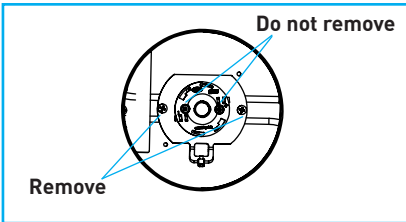

Fig.40

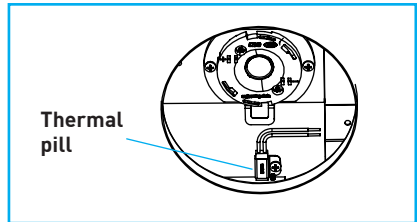

Fig.41

### 3. DRIVER REPLACEMENT

A. Driver assembly is accessed through housing aperture. With LED engine disconnected, pull on sleeved wires to release driver assembly.

**Important:** Wallwash housings may require removal of LED assembly before removing driver. Adjustable housing requires fixture to be tilted and aimed towards power supply.

B. Rotate driver assembly as required to facilitate guiding down, through and just below trim aperture.

C. Disconnect driver wiring from push-in connectors to free assembly from housing.

D. Remove driver assembly and replace with OEM driver sourced through Lucifer Lighting.

E. Connect driver wiring to 2-pin push-in connectors from housing.

F. Guide driver assembly back through trim aperture and return to original position within housing.

G. Attach LED wiring to the corresponding 2-pin lever-nut connectors, Red to Red (+), Black to Black or Blue (-).

H. Raise baffle into aperture, and push up until baffle locks into place.

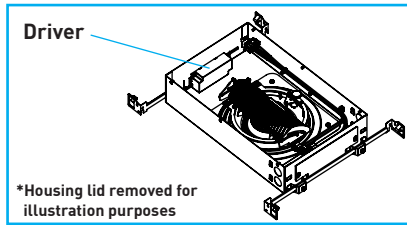

Fig.42

### 4. FIELD PAINTING OF TRIM

**Important:** Though we strongly recommend custom paint be applied by factory during manufacturing, trim and baffle may be field painted without impacting factory mechanical warranty using following guidelines:

A. Recommend specifying **RMP-F4R** (round) or **RMP-F4S** (square) aperture plug.

B. Select paint suitable for application and location of trim, recognizing that Lucifer Lighting Company fixtures are tested not to exceed temperatures of 90° Celsius. Typical operating temperature of faceplate is 46° Celsius nominal.

C. Trim plate surface must be properly prepped in accordance with paint manufacturer's instructions. Paint supplied and furnished by customer.

D. Apply paint to trim flange and interior of baffle only. Minimal tolerance exists between baffle and flange. Excess paint buildup may interfere with baffle installation.

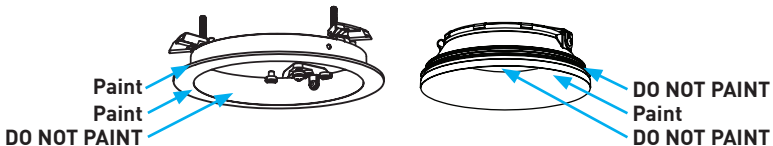

## J. DRIVER WIRING DETAIL

### GENERAL WIRING NOTES

1. Consult approved dimmer list to ensure compatibility.
2. Install in accordance with manufacturer's dimmer installation guidelines.
3. Secondary and 0-10V connections are polarity sensitive.

### WIRING DIAGRAM FOR LINE DIMMING

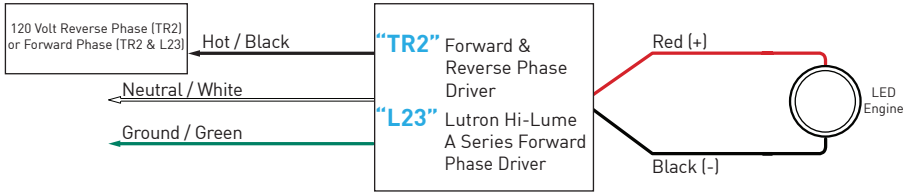

### WIRING DIAGRAM FOR ANALOG CONTROL

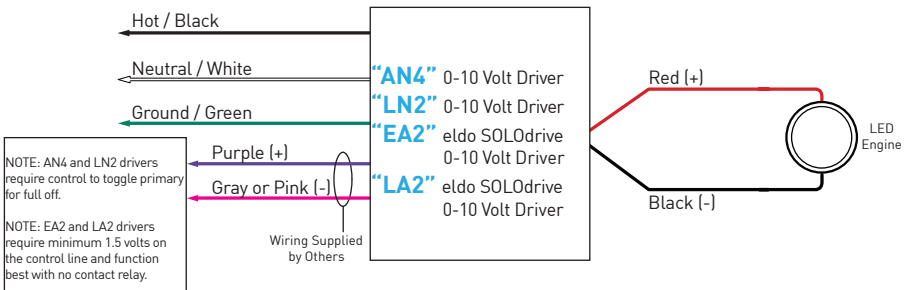

### WIRING DIAGRAM FOR ECOSYSTEM AND DIGITAL CONTROL

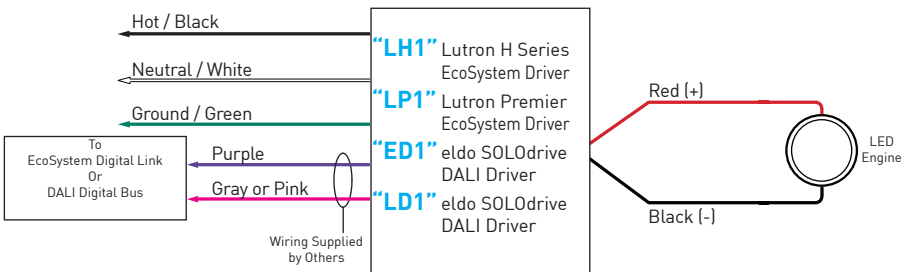

## WIRING DIAGRAM FOR TUNABLE WHITE ANALOG CONTROL

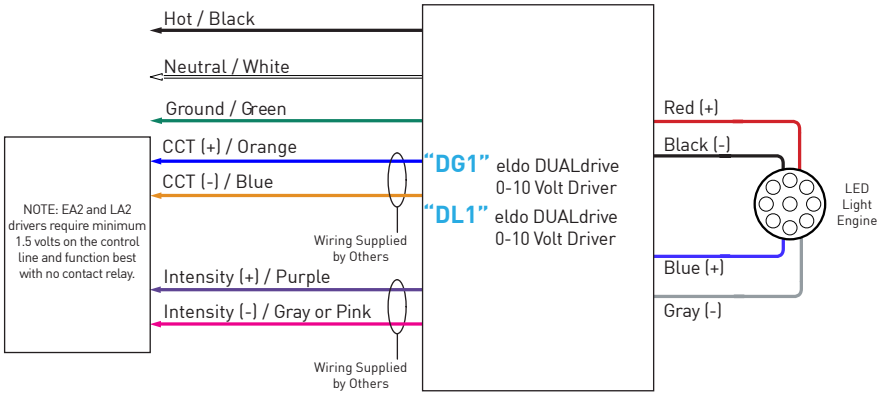

## WIRING DIAGRAM FOR TUNABLE WHITE DALI CONTROL

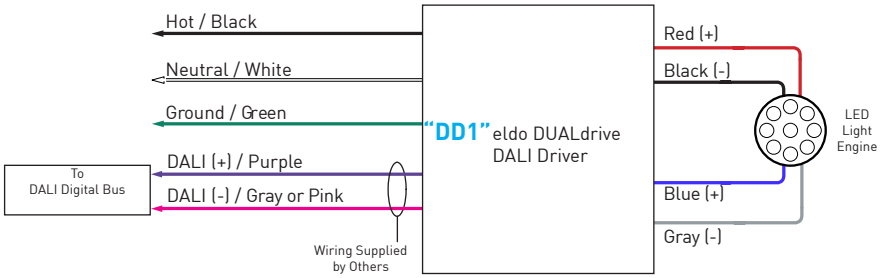

Please consult website for full warranty terms and conditions:  
[www.luciferlighting.com/warranty](http://www.luciferlighting.com/warranty)

[11112021]  
 3750 North PanAm Expressway  
 San Antonio, TX 78219 USA  
 [PH] +1 210 227 7329  
 [FAX] +1 210 227 4967  
[www.luciferlighting.com](http://www.luciferlighting.com)

**LUCIFER**®  
 LIGHTING COMPANY  
 ©2021 Lucifer Lighting Company  
 As part of its policy of continuous research and product development, the Company reserves the right to change or withdraw specifications without prior notice.