

FRAXION® INTERNATIONAL

FRAXION 3 / FRAXION 4 RECESSED LED DOWNLIGHT FITTINGS

INSTALLATION

Before beginning any DOWNLIGHT installation, disconnect electrical power at main switch or circuit breaker.

A. CAUTIONS

To reduce the risk of fire, electric shock, and potential damage to recessed housing assembly when electrical power is re-connected, DO NOT ATTEMPT TO CONNECT the following on branch circuit serving recessed downlight assembly:

- Motors
- Power tools
- Extension cords
- Appliances or similar electronics

Downlight fittings to be mounted in ceiling/plenum conditions *where ambient temperatures do not exceed 40°C.*

Lucifer Lighting LED downlights must be used with Lucifer Lighting mounting components.

Ensure AC input voltage is protected against surges & load shifts prior to power supply input.

B. SAFETY INSTRUCTIONS

1. Read installation instructions completely before attempting installation.
2. Failure to follow instructions may result in improper installation and void warranty.
3. Contact Lucifer Lighting Company with any questions or concerns before beginning any installation.
4. Ensure qualified electrician will perform all electrical procedures.
5. Disconnect electrical power circuit before attempting to install recessed downlight fitting, or if adding to or changing configuration of downlight fitting assembly.

6. Install / mount recessed downlight fitting assembly on structurally sound surface.
7. [Spacing Requirements \(diagram on next page\):](#)

Minimum 168mm (6.63") radius setback from combustible and non-combustible materials from fitting centerline and **19mm (.75")** clearance from top of fitting.

Minimum 76mm (3") clearance from surfaces of power supply / junction box.

Minimum 229mm (9") setback from insulation material having max R-Value of 30 from sides of downlight fitting assembly.

Minimum 305mm (12") setback from polycell foam insulation materials (any type) having max R-Value of 40 and sides of downlight fitting assembly.

Consult factory for spacing requirements for any installations exceeding R-Value of 40.

8. Do not attempt this installation if you do not understand these instructions.

Spacing Requirements:

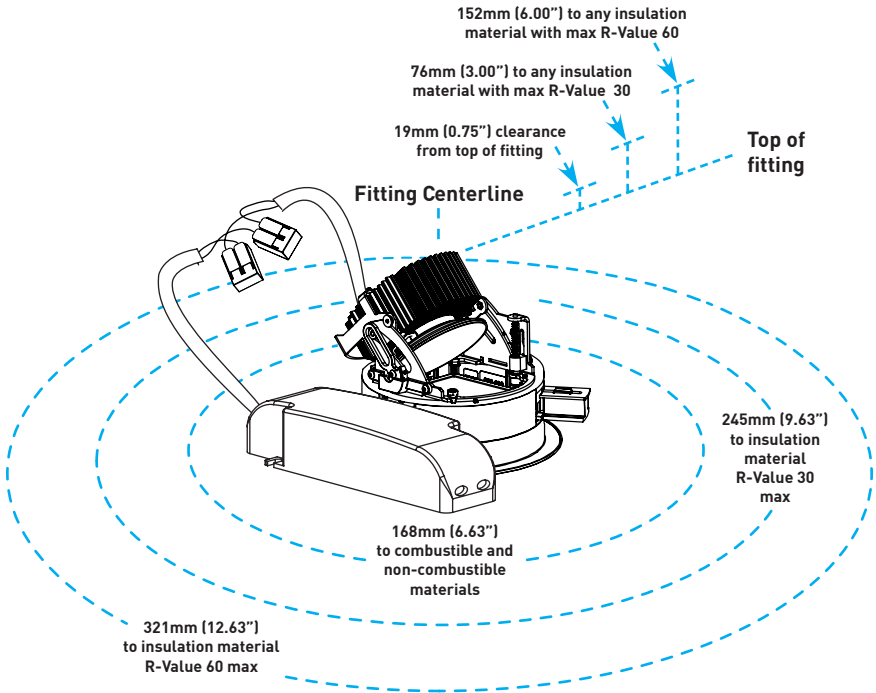

C. WIRING

1. GENERAL WIRING NOTES

Note: Note: Consult Safety Instructions in Section "B. SAFETY INSTRUCTIONS" prior to commencing wiring or servicing.

The downlight fitting assembly should be installed by a registered electrician and shall comply with national and local codes and ordinances .

The installer of the downlight fitting assembly is responsible for furnishing proper electrical equipment and materials for the installation of the downlights as intended by these installation instructions.

Install downlight fitting and supply sufficient length mains voltage wiring to permit access to components and splice connections, which may require future servicing.

Metal conduit shall be used if required by applicable codes. The conductor insulation must feature the appropriate temperature rating as specified on the label for each Lucifer Lighting Company downlight assembly.

Attach protective earth grounds to driver, as apply. No part of the secondary circuit shall be grounded.

For systems that will be dimmed, consult controls manufacturer to verify driver compatibility and proper installation procedures and parameters.

D. CEILING SUBSTRATE AND FINISH OUT

1. GENERAL MOUNTING NOTES

Recessed downlight fitting /power supply assemblies are thermally protected. Cycling fitting may indicate improper installation, inadequate plenum space surrounding fitting or incompatible higher wattage LED for specified driver. Verify insulation spacing complies with required setbacks (see pages 1-2) and LED's wattage is suitable for driver.

Determine specified fitting location, ensuring sufficient space exists to accommodate assembly components (see pages 1-2).

2. CEILING THICKNESS

Fittings compatible with 3.2mm (0.125") to 32mm (1.25") ceilings. Deep regress fittings can accommodate up to **63mm (2.50") for Fraxion 4** or **51mm (2.00") for Fraxion 3**.

3. CEILING CUTOUTS

Factory recommends use of properly sized hole saw for cut-outs. Correct size and quality of hole is critical for installation.

Make proper hole cut-out, referencing measurements from adjacent walls to aperture centerline.

FRAZION 4 CEILING CUT-OUT:

114mm (4.50") diameter for round fittings
114mm (4.50") Sq. for square fittings

FRAZION 3 CEILING CUT-OUT:

86mm (3.375") diameter for round fittings
86mm (3.375") Sq. for square fittings

4. PLASTERBOARD

Important: Square fitting installations require final alignment. Utilize string line or laser line to obtain uniform or desired alignment between multiple fittings or in relation to parallel planes.

Install plasterboard in typical fashion. Oversized hole cut-outs must be filled in with mud or plaster, utilizing appropriate tape in accordance with industry standards, prior to fitting installation.

Note: For mud-in plasterboard installations, see Section F.3.

Important: If mud-in, appliqué must be installed prior to mudding or finishing of ceiling. Failure to follow these instructions will lead to failed expectations and added expense.

Sand, prime, and apply finish coat to ceiling.

5. WOOD CEILING

Install wood in accordance with local and national building codes, employing suitable fire barriers as required. Hole cut-outs should be clean and precise. Sand, stain and apply finish seal coat prior to installing fitting, on flange overlay applications, or baffle, on Trimless Wood applications.

Important: Trimless installations are not compatible with wood ceiling applications.

6. T-GRID LAY-IN TILE CEILING

Install tiles in accordance with manufacturer's recommendations.

Important: Trimless installations are not compatible with lay-in tile ceiling applications.

E. POWER SUPPLY INSTALLATION

1. INSTALL POWER SUPPLY

Remove splice compartment cover, gaining access to wiring compartment of power supply *"Fig.1"*.

Driver assembly provides integral wiring terminal *"Fig.1"* and typically accepts 3 wires for connecting to the mains voltage: Black (Line / Hot / Switching), White (Common) and Green (Protective Earth Ground).

Use appropriate raceway, connectors, wire and strain reliefs as required.

Note: Improper polarity may cause damage to the unit and can void the warranty.

Consult wiring diagrams in Section "K. WIRING DIAGRAMS", joining structured building wires to corresponding driver terminals.

Carefully raise finished power supply up through ceiling cutout, and rest atop ceiling *"Fig.2"*.

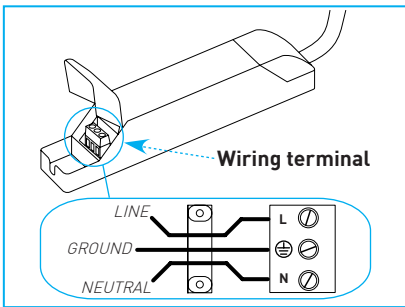

Fig.1

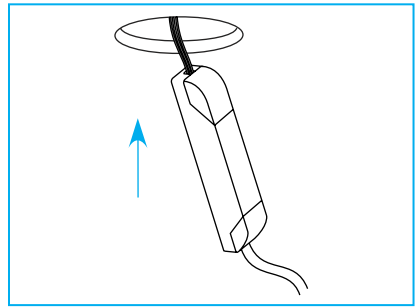

Fig.2

F. FITTING INSTALLATION

Ensure ceiling is finished before beginning fitting installation.

1. CONNECT WIRING

Attach LED wiring to the corresponding 2-pin lever-nut connectors *"Fig.3"*. Red to Red (+), Black to Black or Blue (-).

Warning: Connections are polarity sensitive.

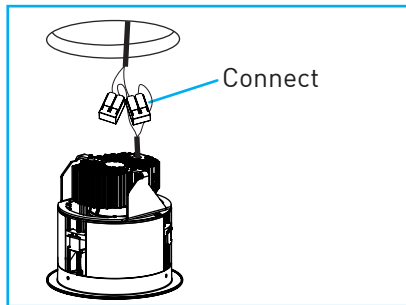

Fig.3

2. FLANGED

The following instructions are for Standard Flange and MicroFlange fittings, assuming housing or remodel power supply has been installed with initial alignment completed and/or proper ceiling cut-out has been made ready to accept fitting. For Trimless fitting installations, see Section F.3.

For ceiling thickness of .50" and below, employ plastic spacers "Fig.4".

Retract retaining tabs into aperture of fitting "Fig.5". Raise fitting to housing and join corresponding fitting and housing wires with supplied lever-lock connectors, ensuring proper polarity is observed. Continue raising fitting into housing and extend retaining tabs, tightening retaining tab screws until fitting seats flush to ceiling "Fig.6".

WARNING: Do not tighten retaining tab screws using a powered screwdriver.

Square fittings require alignment. With retaining tabs loosened slightly, use string line or laser level to obtain uniform or desired alignment between multiple fittings or adjacent wall planes. Tighten retaining tab screws when complete, seating fitting firmly to ceiling "Fig.6 & Fig.7".

WARNING: Do not tighten retaining tab screws using a powered screwdriver.

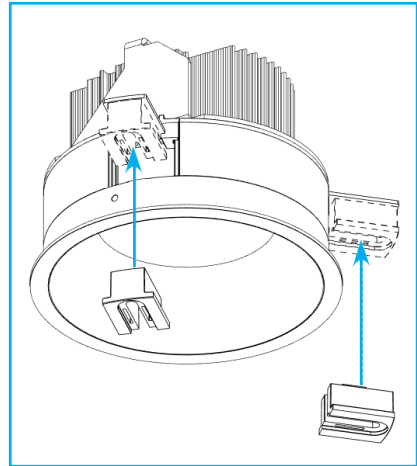

Fig.4

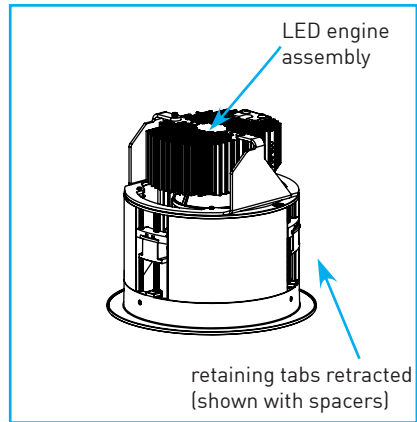

Fig.5

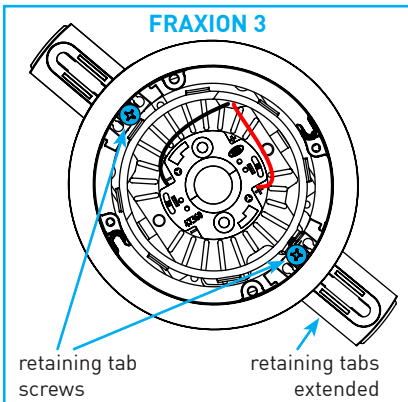

Fig.6

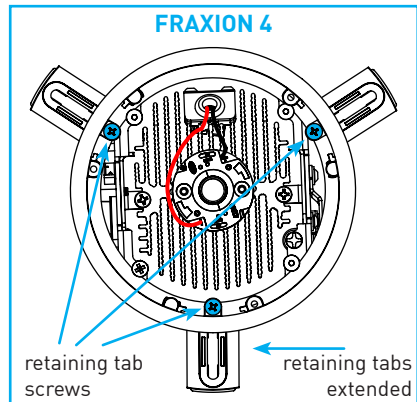

Fig.7

3. TRIMLESS DRYWALL

The following instructions assume housing has been installed with initial alignment completed and/or proper ceiling cut-out has been made ready to accept fitting with attached appliqué.

With Housing: For installations utilizing a downlight housing, remove baffle and retract retaining tabs into fitting aperture. Raise fitting mechanism with attached appliqué, joining the corresponding fitting and driver wires with the supplied connectors. Continue raising appliqué assembly into housing collar. Extend retaining tabs to hold fitting in place, tightening to seat firmly after final alignment *"Fig.8"*.

Without Housing: For remodel or tethered power supply installations, remove baffle and retract retaining tabs into fitting aperture. Raise fitting mechanism with attached appliqué, joining the fitting and power supply coupler. Continue raising applique assembly into ceiling cut-out. Extend locking tabs to hold fitting in place, tightening to seat firmly after final alignment *"Fig.9"*.

Tighten retaining tab screws until appliqué is firmly seated against ceiling surface.

Important: Square appliqués require alignment. With retaining tabs loosened slightly, use string line or laser level to obtain uniform or desired alignment between multiple fittings or adjacent wall planes. Tighten retaining tab screws when complete *"Fig.10"*.

WARNING: Retaining tab screws must be hand tightened.

After fitting is secured, install plaster plug *"Fig.11"*. Apply tape over finger pull to protect optic and LED. Do not remove plug until all plaster and paint work is complete.

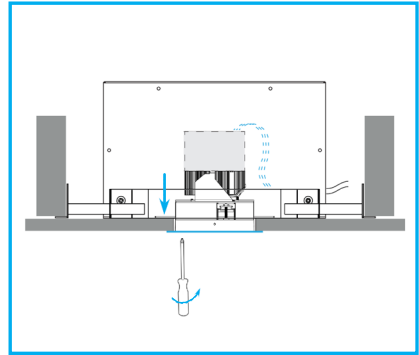

Fig.8

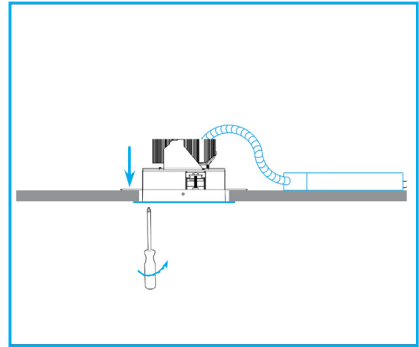

Fig.9

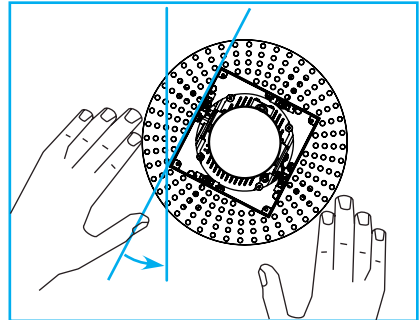

Fig.10

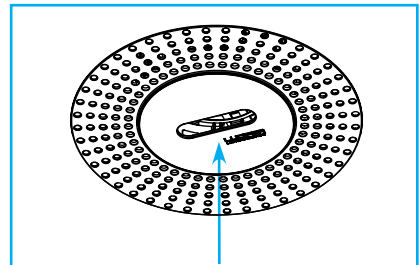

Fig.11

Use floating knife to apply first coat of drywall compound from beyond outer edge of appliqué to inner edge of appliqué / plaster stop. Float out as far as necessary to hide perforated appliqué "Fig.12".

Apply subsequent coats of drywall compound as required, using screed edge as a guide, feathering out and away from the appliqué to create the appearance of a perfectly flat ceiling "Fig.13". Allow joint compound to dry fully between coats.

Gently use block sanding screen to sand surface until desired level of smoothness is achieved "Fig.14".

WARNING: An unsatisfactory installation will occur if drywall compound is not sufficiently sanded and the flange / plaster stop is at all receded into the ceiling plane.

Once cured, the ceiling may be painted. After paint is dry, remove plaster plug.

Check for any drywall compound or paint that may have seeped beneath plug and carefully scrape if necessary.

Important: Any foreign material left in or on recessed appliqué surface may prevent proper fitting installation and satisfactory trimless appearance.

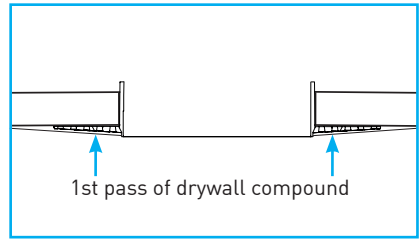

Fig.12

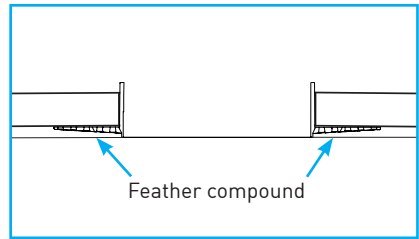

Fig.13

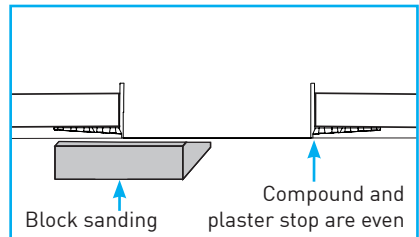

Fig.14

G. OPTIC INSTALLATION

1. INSTALL OPTIC

Secure optic to LED module by aligning two locking tabs and twisting clockwise "Fig.15".

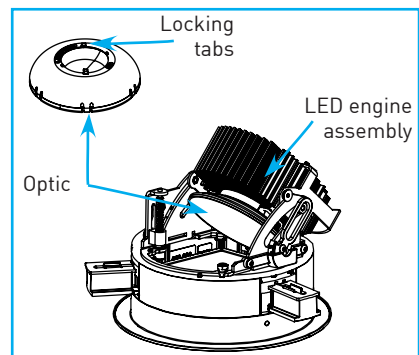

Fig.15

H. ADJUSTABLE FITTINGS

Adjustable fittings feature hot-aiming 40° tilt and 365° rotation.

1. TILT

To adjust, use a standard #2 Phillips-head or flat-blade screwdriver. Locate black crossed-slot screw, rotating counter-clockwise to increase tilt and clockwise to decrease tilt *"Fig. 16 & Fig. 17"*.

DO NOT TURN SCREW PAST LIMITS OF ADJUSTMENT. May result in damage to mechanism.

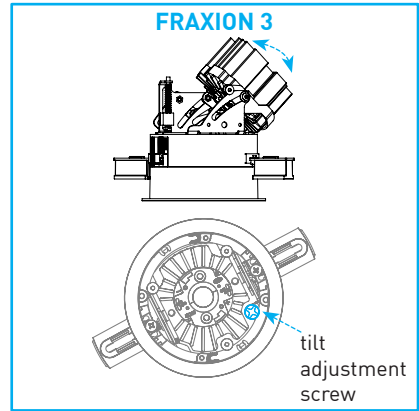

Fig.16

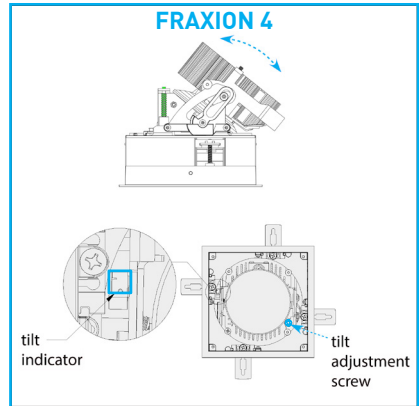

Fig.17

2. ROTATION

To adjust, locate silver lock screw and loosen with standard #2 Phillips-head screwdriver. Set desired position by hand with gentle outward force of fingers in fitting aperture, turning to desired orientation. Tighten lock screw to secure *"Fig. 18"*.

DO NOT OVER-TIGHTEN.

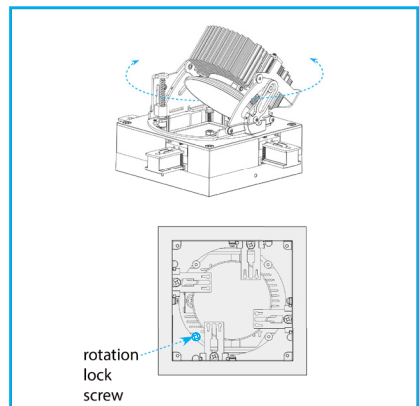

Fig.18

3. ADJUSTABLE HCL ASSEMBLY

Allows for Honeycomb Louver and a secondary effects device to tilt and rotate with adjustable fittings.

Install HCL and specified secondary effects device in retainer, ensuring the HCL is installed first "Fig.19".

With aiming completed and optic installed, raise assembly up and carefully clip onto optic "Fig.20".

WARNING: Ensure standard effects device and lens retainer are not installed on baffle prior to installation.

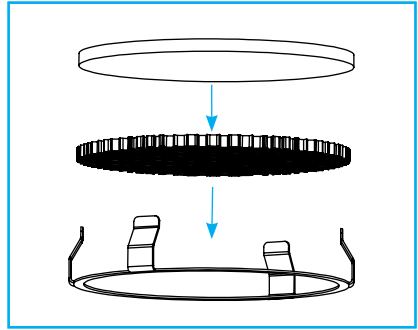

Fig.19

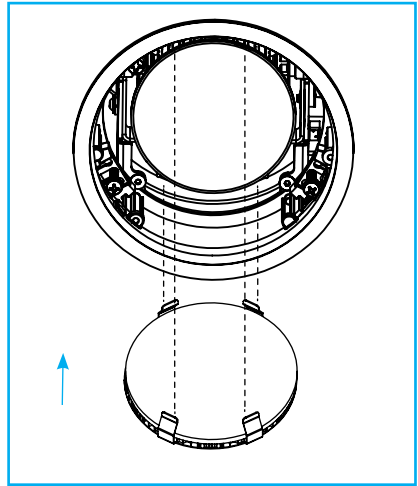

Fig.20

I. BAFFLE INSTALLATION

1. INSTALL BAFFLE

Raise baffle into fitting aperture, and push up until baffle sits flush with flange. "Fig.21".

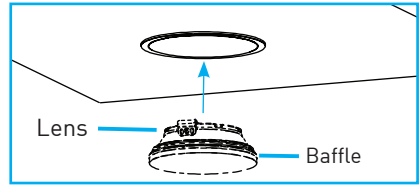

Fig.21

Wallwash Fittings: Baffle "Fig.22" requires alignment with light source. To achieve proper wallwashing, ensure the baffle and fitting are oriented to direct light toward the desired wall "Fig.23".

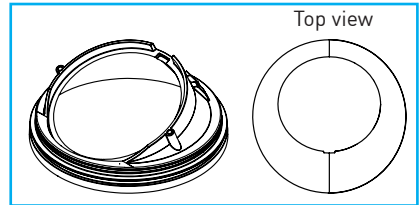

Fig.22

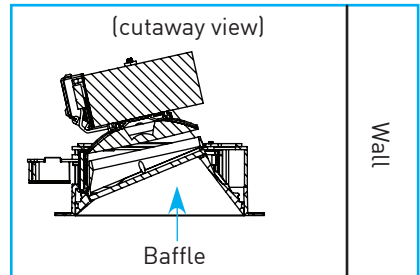

Fig.23

J. SERVICING FITTING

Important: Before servicing or maintaining fitting, disconnect electrical power at main switch or circuit breaker. Additionally, heed all WARNINGS and CAUTIONS, review the Safety Instructions, and refer to figures in main installation instructions where necessary.

1. EXCHANGING OPTIC / EFFECTS DEVICES

A. Remove baffle. Dry location baffles are removed by lifting lens and pulling down on the top of baffle. Wet location baffles or those with sealed lenses are removed by pulling down on the lens with a suction cup. Wallwash baffles require inserting small flat head screwdriver and carefully prying down as shown in "Fig.24".

B. To change optic, carefully grab and twist counter-clockwise to remove and clockwise to secure. Ensure that both feet of optic properly engage LED base.

C. To change lens / film, remove lens retainer and gasket by loosening and removing screw. Insert preferred lens / film in proper orientation, securing with lens retainer / gasket and replacing and tightening screws "Fig.25".

D. Raise baffle into aperture, and push up until baffle locks into place.

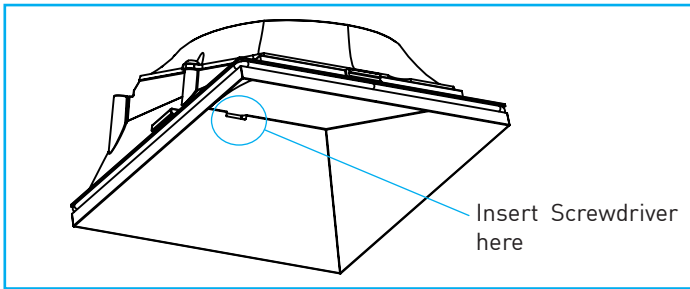

Fig.24

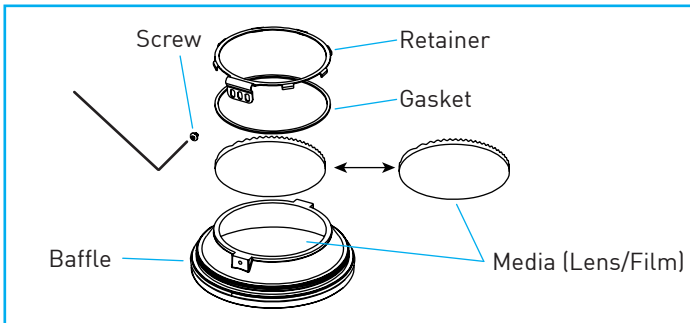

Fig.25

2. REPLACING LED ENGINE ASSEMBLY

A. Remove engine from ceiling using following techniques for the respective trim type:

1. Standard Flange / MicroFlange Trims

- Grasp baffle using soft gloves or with clean soft cloth and remove by pulling down or inserting small flat head screwdriver to wallwash baffles and carefully prying down *"Fig.22"*.
- Remove optic by twisting counter-clockwise.
- Using standard Phillips-head screwdriver, loosen black locking screws from retaining tabs within trim aperture.
- Applying upward pressure to support weight of trim, slide retaining tabs so that they are entirely retracted within trim aperture.
- Remove trim through aperture.
- Using standard Phillips-head screwdriver, remove 2 silver screws from black heat sink to detach LED engine from trim *"Fig.26"*.

2. Trimless

- Grasp baffle using soft gloves or with clean soft cloth and remove by pulling down or inserting small flat head screwdriver to wallwash baffles and carefully prying down *"Fig.22"*.
- Remove optic by twisting counter-clockwise.
- Applying upward pressure to support weight of LED engine, use standard Phillips-head screwdriver, remove 2 silver screws from black heat sink to detach LED engine from trim *"Fig.26"*.
- Remove LED engine through trim aperture.

B. Release trim from wiring harness by releasing trim wiring from lever lock connectors, or disconnecting 4-pin tunable white connectors. For remodel trims equipped with flexible conduit, locking latch on conduit quick-connector will first need to be dislodged.

C. Replace with new OEM LED engine assembly sourced through Lucifer Lighting, reversing order of preceding steps.

D. Ensure that both feet of optic properly engage LED base and twist clockwise to secure.

E. Raise baffle into aperture, and push up until baffle locks into place.

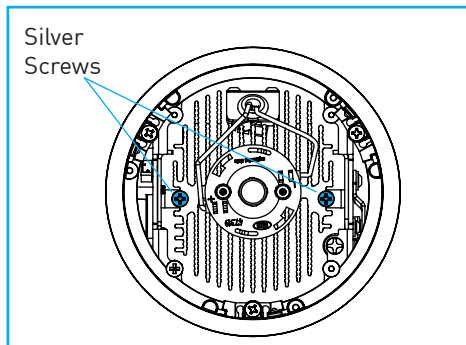

Fig.26

3. DRIVER REPLACEMENT

A. Replace driver using following techniques for the respective installation type:

1. Standard Flange / Microflange / Trimless - Fixed and Wallwash

- With fitting removed, pull wiring harness to facilitate guiding driver down, through and just below ceiling cutout.
- Disconnect driver from line / mains and control wiring as applies.
- Replace with OEM driver sourced through Lucifer Lighting.
- Connect driver to line / mains and and control wiring as applies.
- Guide driver assembly back through ceiling cutout and place atop ceiling.
- Attach LED wiring to the corresponding 2-pin lever-nut connectors, Red to Red (+), Black to Black or Blue (-).
- Reinstall fitting.
- Raise baffle into aperture, and push up until baffle locks into place.

2. Trimless - Adjustable

- Remove adjustment mechanism by loosening locking screw and removing two shoulder screws "Fig.27".
- Pull wiring harness to facilitate guiding driver down, through and just below fitting aperture.
- Disconnect driver from line / mains and control wiring as applies.
- Replace with OEM driver sourced through Lucifer Lighting.
- Connect driver to line / mains and and control wiring as applies.
- Guide driver assembly back through fitting aperutre and place atop ceiling.
- Attach LED wiring to the corresponding 2-pin lever-nut connectors, Red to Red (+), Black to Black or Blue (-).
- Reinstall adjustment mechanism by installing shoulder screws and tightening the locking screw "Fig.25".
- Raise baffle into aperture, and push up until baffle locks into place.

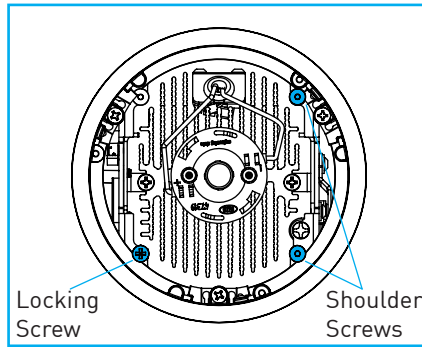

Fig.27

4. FIELD PAINTING OF TRIM

Though we strongly recommend custom paint be applied by factory during manufacturing, trims may be field-painted without impacting factory mechanical warranty using following guidelines:

- Recommend specifying **RMP-F3R / RMP-F4R** (round) or **RMP-F3S / RMP-F4S** (square) aperture plug.
- Select paint suitable for application and location of trim, recognizing that Lucifer Lighting Company fittings are tested not to exceed temperatures of 90° Celsius. Typical operating temperature of faceplate is 46° Celsius nominal.
- Trim plate surface must be properly prepped in accordance with paint manufacturer's instructions. Paint supplied and furnished by customer.

Important: Paint to be applied to trim flange only. Any disassembly or modification to trim or mechanism voids factory warranty and may represent an unsafe operating condition. Minimal tolerance exists between baffle and flange. Excess paint buildup may interfere with baffle installation.

K. WIRING DIAGRAMS

GENERAL WIRING NOTES

1. Consult approved dimmer list to ensure compatibility.
2. Install in accordance with manufacturer's dimmer installation guidelines.
3. Secondary and 0-10V connections are polarity sensitive.

WIRING DIAGRAM FOR ANALOG CONTROL

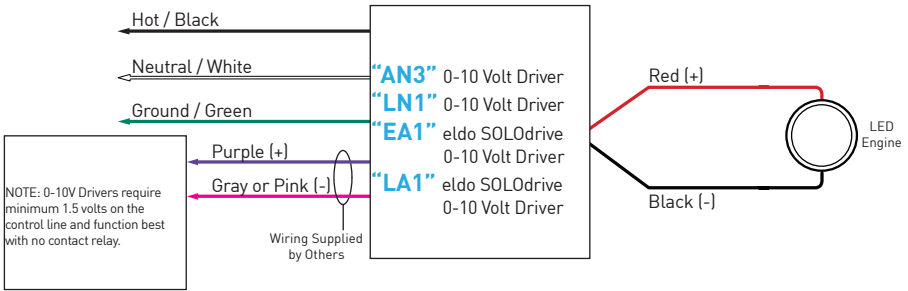

WIRING DIAGRAM FOR DIGITAL CONTROL

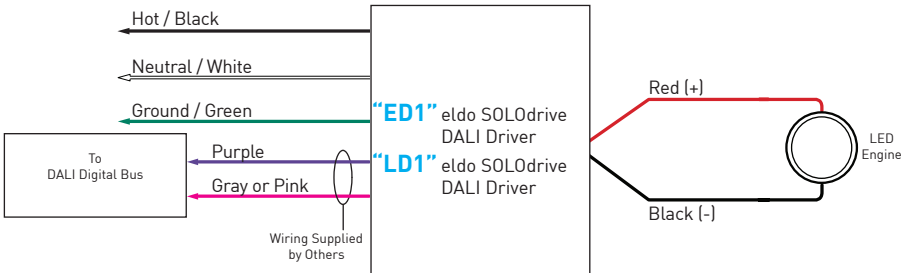

Please consult website for full warranty terms and conditions:

www.luciferlighting.com/warranty

[12132021]

3750 North PanAm Expressway
San Antonio, TX 78219 USA
[PH] +1 210 227 7329
[FAX] +1 210 227 4967
www.luciferlighting.com

LUCIFER[®]
LIGHTING COMPANY

©2024 Lucifer Lighting Company
As part of its policy of continuous research and product development, the Company reserves the right to change or withdraw specifications without prior notice.