

# Atomos<sup>TM</sup>

VERY GOOD THINGS. VERY SMALL PACKAGE.

/ at - OH - mōs /

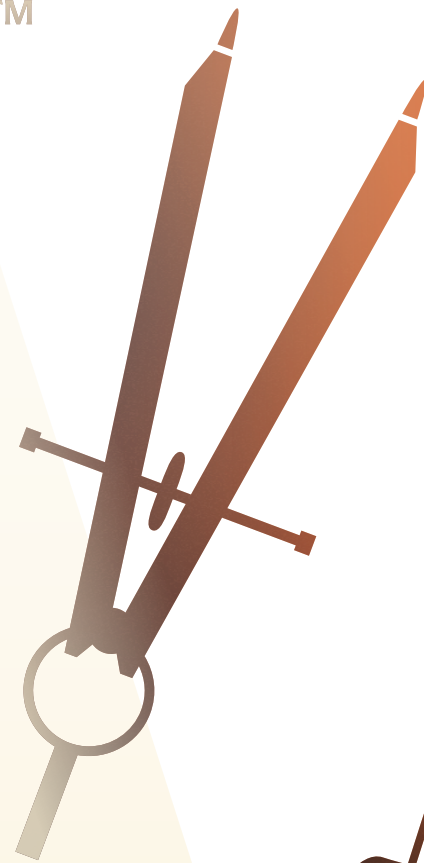
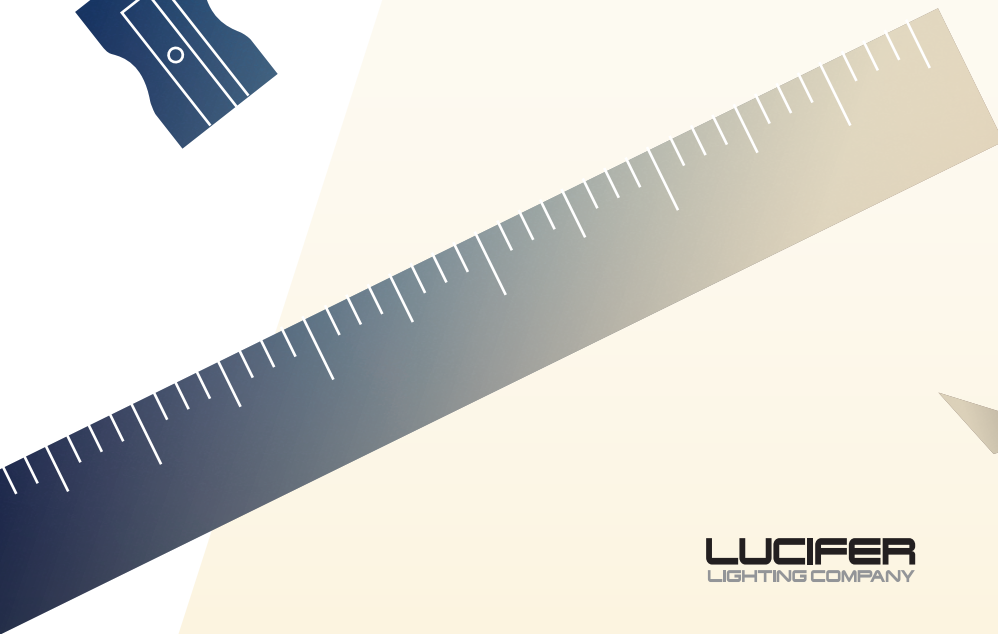
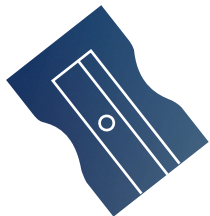

**LUCIFER**  
LIGHTING COMPANY

We keep making our light more beautiful and fixtures more compact. It's what you've come to expect from Lucifer Lighting.



# We've put everything we know about thermals, optics and ease of installation into Atomos, our smallest fixture, yet.

## TINY APERTURES, BIG LIGHT

Available in 2" small aperture and 1" pinhole in both round and square. Five standard finishes and custom finishes available.

1" Pinhole Square

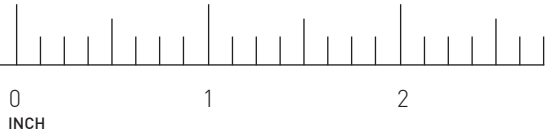

1" Pinhole Round

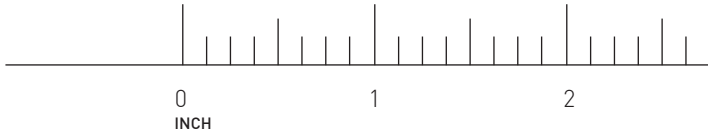

2" Small Aperture Square

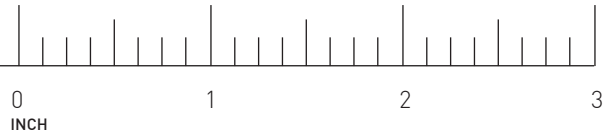

2" Small Aperture Round

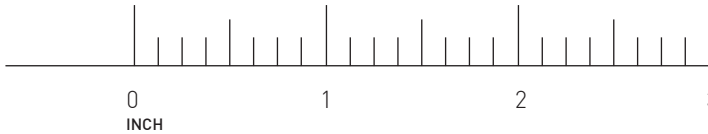

## FIXTURE FINISHES



## SPRING-LOADED RETENTION ROLLERS

Innovative design uses constant force mechanics to keep fixture snug against the ceiling plane. For ceiling thicknesses of 1/2" to 2".

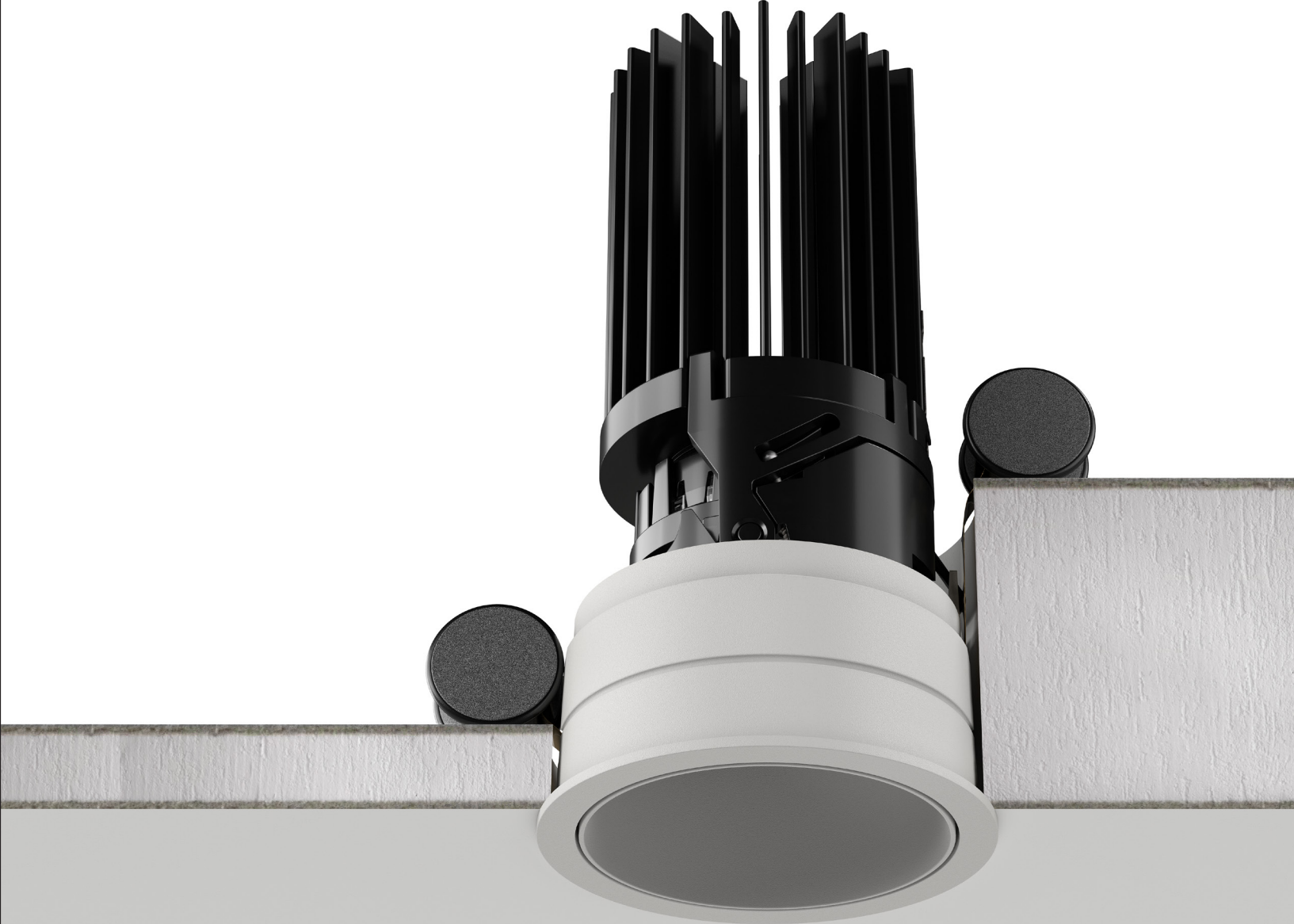

An integrated driver ensures installation ease without sacrificing closet or attic space to store power supplies typically common to other manufacturers.



**FLANGE OPTIONS**

Trimless or overlay flange options for a minimal, modern aesthetic.

**2" FLANGE**

Shown with Round Trim and Round Baffle



**2" TRIMLESS**

Shown with Round Applique and Round Baffle

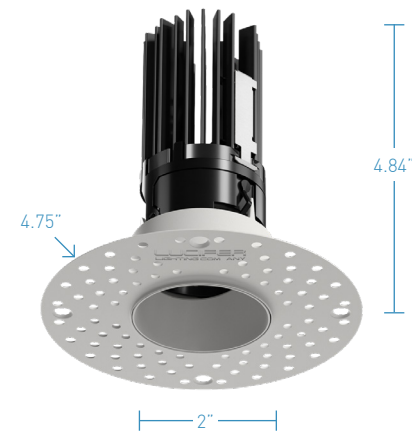

**1" ZERO-SIGHTLINE**

Shown with Square Applique and Square Baffle

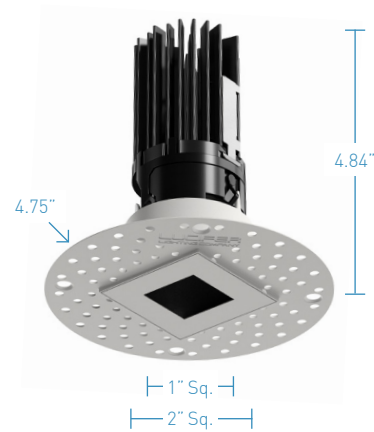

**1" ZERO-SIGHTLINE**

Shown with Pinhole Applique and Pinhole Baffle

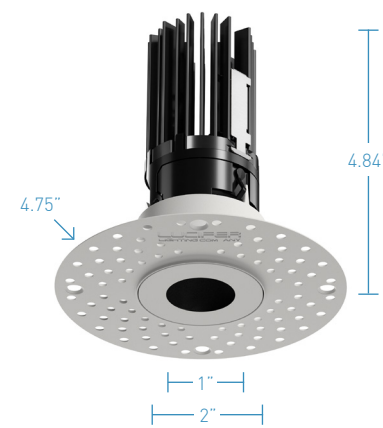

**TRIMLESS MILLWORK**

Available for both 2" Round and Square.



**ZERO-SIGHTLINE MILLWORK**

Available for 1" Round.





Available with a comfortable and smooth warm-dim color profile to make spaces feel inviting and intimate.

# Our special Zoom Optic makes it easy to adjust beam spreads to highlight what's most important.



**ENHANCED ACCESSORY**

Fixture as standard is specifiable with one of five dedicated beam spreads. Zoom Optic is a special adjustable accessory ordered in place of fixed distribution optics to adjust beam spread on site.

**CLICK-TO-SET BEAM SPREADS**

Proprietary, patent-pending technology provides in the field flexibility – just turn the optic and click into any of five, fixed beam spreads.

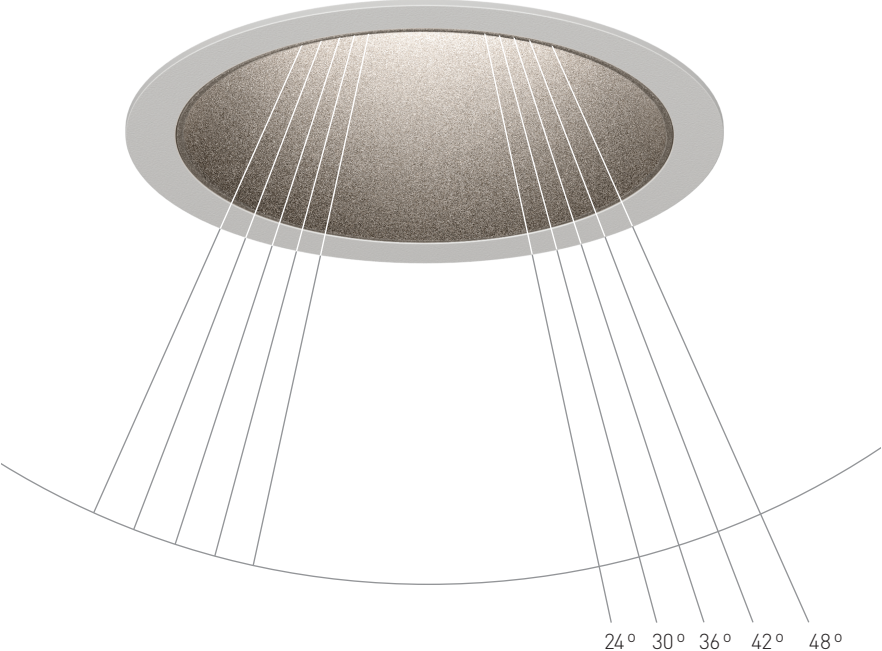

**2" ROUND WALLWASH**



**30" SETBACK / 30" ON CENTER SPACING**

- Average fc: 11.48
- Min / max: 5.81
- 10ft ceiling shown / 8-12ft ideal
- 9 fixtures / 25ft wall shown

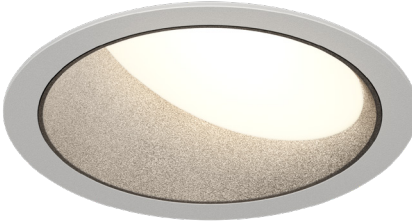

**36" SETBACK / 36" ON CENTER SPACING (RECOMMENDED)**

- Average fc: 9.26
- Min / max: 5.30
- 10ft ceiling shown / 8-12ft ideal
- 9 fixtures / 30ft wall shown

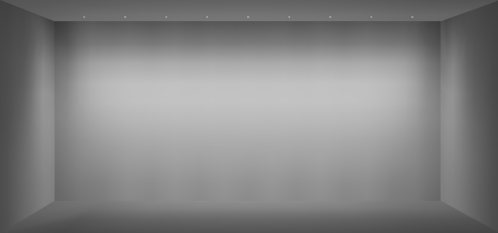

**42" SETBACK / 42" ON CENTER SPACING**

- Average fc: 7.22
- Min / max: 7.60
- 10ft ceiling shown / 8-12ft ideal
- 9 fixtures / 35ft wall shown

**2" SQUARE WALLWASH**



**30" SETBACK / 30" ON CENTER SPACING**

- Average fc: 12.64
- Min / max: 4.83
- 10ft ceiling shown / 8-12ft ideal
- 9 fixtures / 25ft wall shown

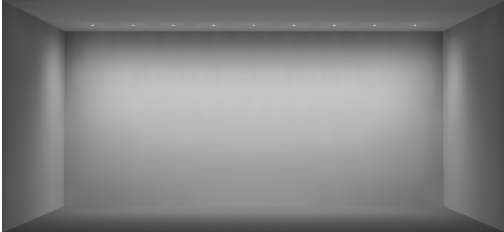

**36" SETBACK / 36" ON CENTER SPACING (RECOMMENDED)**

- Average fc: 11.30
- Min / max: 4.46
- 10ft ceiling shown / 8-12ft ideal
- 9 fixtures / 30ft wall shown

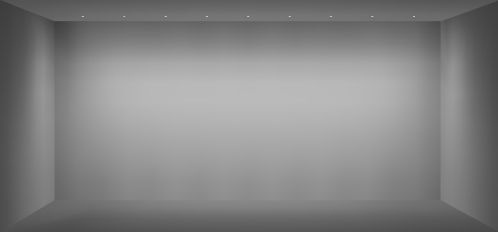

**42" SETBACK / 42" ON CENTER SPACING**

- Average fc: 8.07
- Min / max: 5.76
- 10ft ceiling shown / 8-12ft ideal
- 9 fixtures / 35ft wall shown

Whether for new construction or remodel projects anywhere in the world, these tiny apertures provide discrete aesthetics with impressive performance.





# Bright but dimmable – our LEDs bring consistent cool or warm inviting light to life.

## COLOR TEMPERATURES

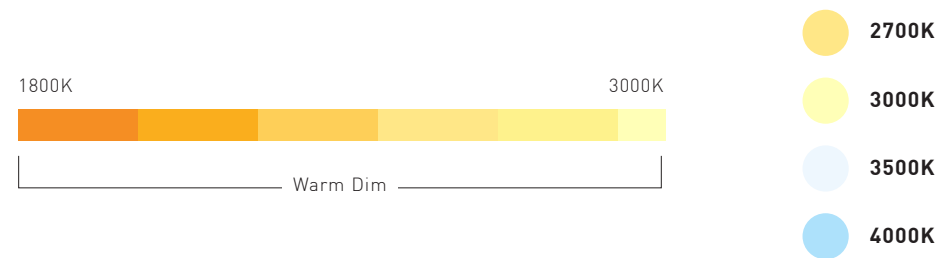

## PHOTOMETRY

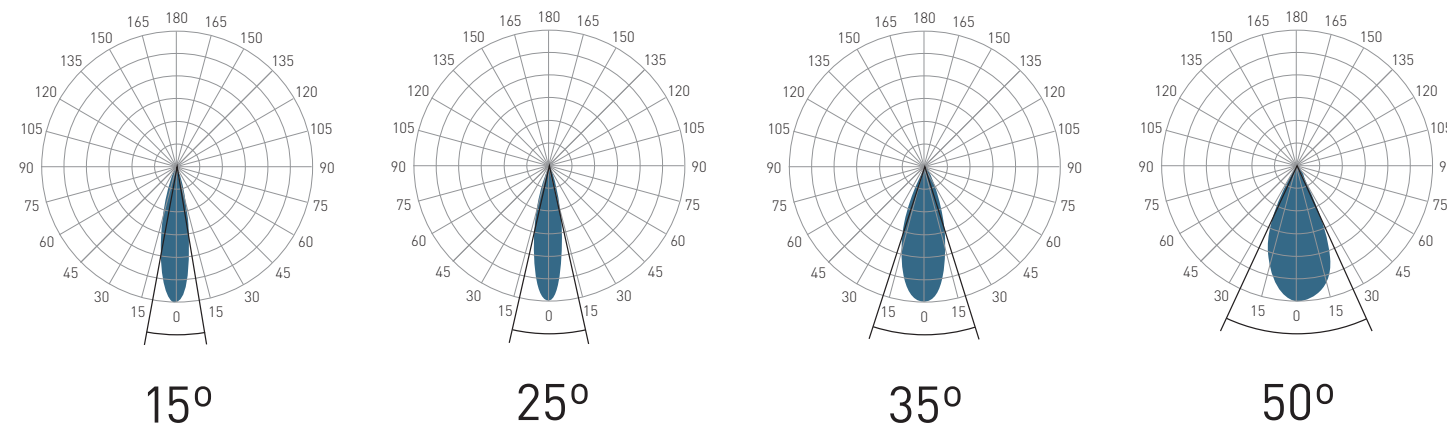

## WARM DIM

### WARM DIM PROFILE

9009D 3000K - 1800K	Full on 100%	Dimmed to 80%	Dimmed to 70%	Dimmed to 50%	Dimmed to 20%	Dimmed to 10%	Dimmed to 2%
CCT (K)	3000	2900	2850	2550	2000	1900	1800
Light Output (Lm)	587	470	411	294	117	59	12
Power (W)	12	9.6	8.4	6.0	2.4	1.2	0.2
Efficacy (LPW)	49	49	49	49	49	49	49

### WARM DIM PERFORMANCE SOFT FOCUS FILM

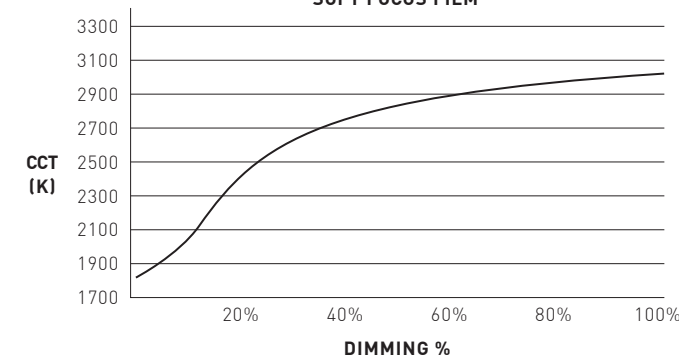

## ORDERING SHEET

Trim	Trim Type	Fixture Type	Rating	Trim Finish	Baffle Finish	Lumen Package	CCT	Optic	Install Type	Driver	Effects Device
A2RS 2" Round Standard A2SS 2" Square Standard	F Flange Overlay T Trimless Drywall W Trimless Wood	AD Adjustable* *(0° - 30° tilt)	1 Dry/Damp (IP20) 2 Wet (IP44)	WH White	WH White	<b>STATIC WHITE</b> <b>8012D</b> 80+CRI, Delivered Lumens - 912 <b>9010D</b> 90+CRI, Delivered Lumens - 773	27 2700K	15 15°	<b>13mm - 50mm MAX CEILING THICKNESS</b>  E Export *(For export use, outside of USA)	IP ELV/Triac, 1% ID DALI, LOG, 1% IN DALI, LIN, 1%	<b>STANDARD</b> 4 Soft Focus Film  <b>ALTERNATIVE</b> 0 No Media* *(Not available for Wet Location or Warm Dim) 2 Honeycomb Louver* *(Not available for Wet Location or Warm Dim) 3 Clear Film* *(Not available for Warm Dim) 5 Asymmetric Film S Honeycomb Louver w/ Soft Focus Film C Honeycomb Louver w/ Clear Film* *(Not available for Warm Dim)
				AG Satin Silver AU Cashmere Gold BB Burnt Bronze BK Black PR Primer OO Trimless* *(Required for trimless) CF Custom Finish* *(Consult factory)	AG Satin Silver AU Cashmere Gold BB Burnt Bronze BK Black PR Primer CF Custom Finish* *(Consult factory)		30 3000K 35 3500K 40 4000K	25 25° 35 35° 50 50°			
						<b>WARM DIM</b> <b>9009D</b> 90+CRI, Delivered Lumens - 663	WD 3000K-1800K	15 15° 25 25° 35 35° 50 50°			

\* All delivered lumen outputs and T24 compliance reflect 3000K paired with 25° optic and soft focus film.

[WH] White Powder Coat	[AG] Satin Silver Powder Coat	[AU] Cashmere Gold Powder Coat	[BB] Burnt Bronze Powder Coat	[BK] Black Powder Coat

**PART NUMBER NOTES**  
Trim ships as e.g., A2RSFAD1AGAG-8012D27-15E-IP\*0

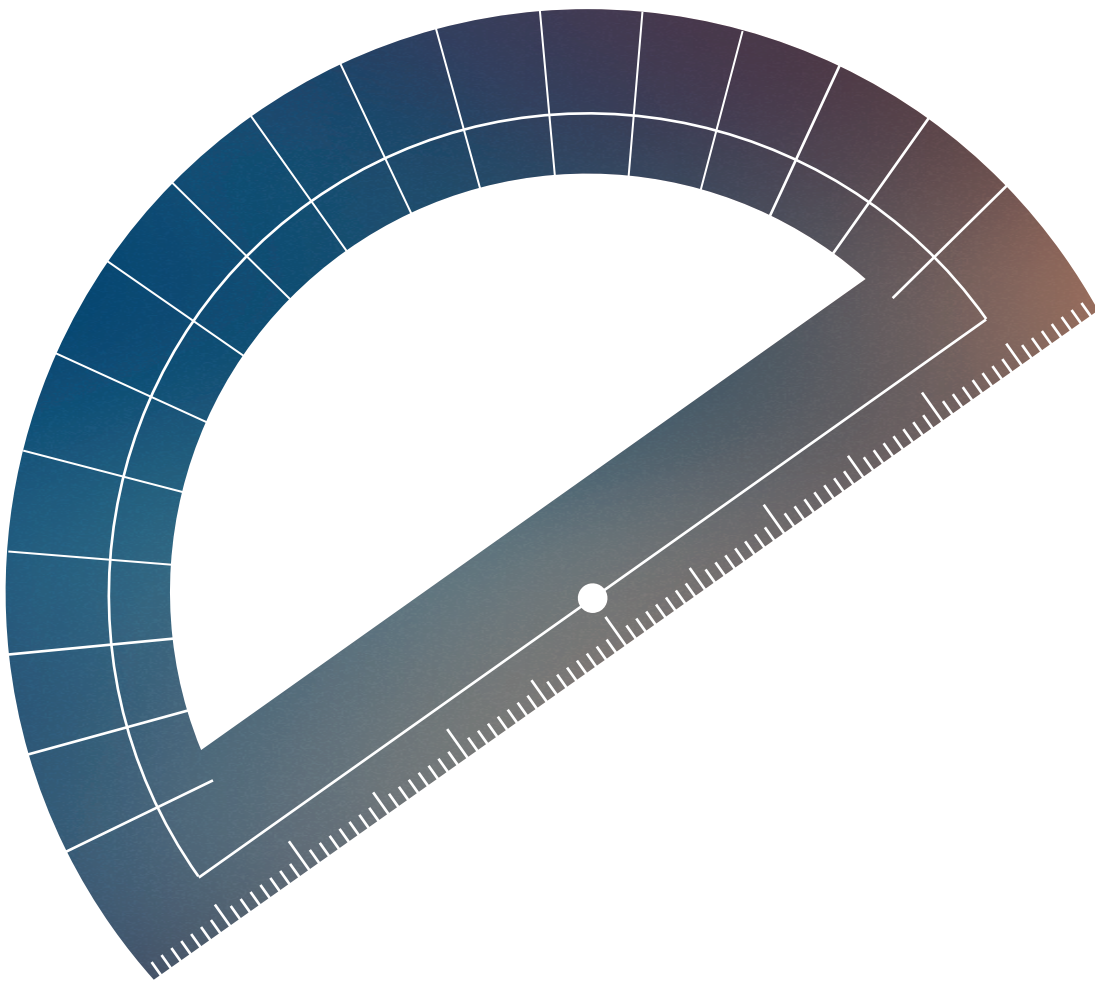
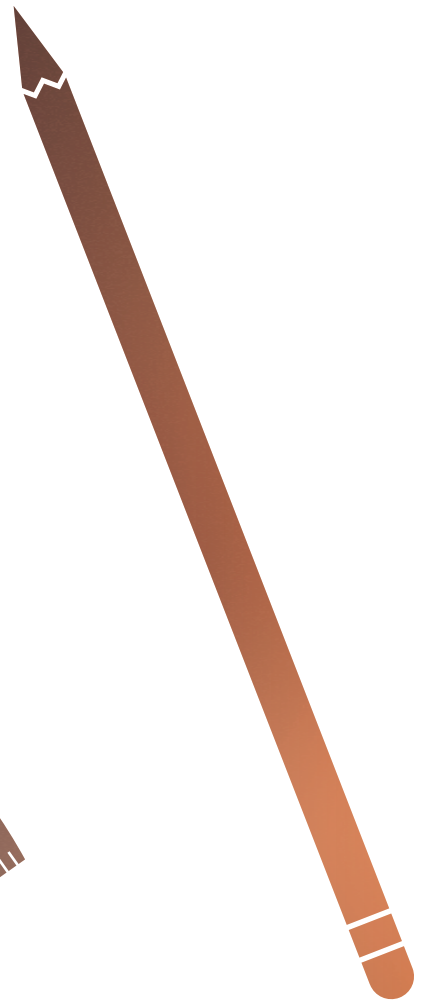
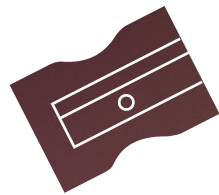

**LUCIFER**  
LIGHTING COMPANY

[luciferlighting.com](http://luciferlighting.com)

©2021 Lucifer Lighting Company. All rights reserved.