

# CYLINDER SURFACE MOUNT

## CYLINDER LED LUMINAIRE CYX / CPX / CDX SERIES

### INSTALLATION

Before beginning any CYLINDER installation, disconnect electrical power at main switch or circuit breaker.

#### A. CAUTION

To reduce the risk of fire, electrical shock, and potential damage to these fixtures when electrical power is supplied, DO NOT CONNECT the fixtures on branch circuits serving the following:

- Motors
- Power tools
- Extension cords
- Appliances or similar electronics

Fixtures to be mounted in conditions where ambient temperatures do not exceed 40°C.

Fixtures must be installed on phase-balanced AC circuits, protected against transient power surges or spikes.

#### B. SAFETY INSTRUCTIONS

1. Read installation instructions completely before attempting installation.
2. Failure to follow instructions may result in improper installation and void warranty.
3. Contact Lucifer Lighting Company with any questions or concerns before beginning any installation.
4. Ensure qualified electrician will perform all electrical procedures.
5. Disconnect electrical power circuit before attempting to install Cylinder, or if adding to or changing configuration of Cylinder assembly.
6. CAUTION: When fixture is on for long periods the Cylinder surface will be hot. Take care when making adjustments.

This product must be installed in accordance with applicable electrical and installation codes by a person familiar with the construction and operation of the product and the hazards involved. "CAUTION- RISK OF FIRE"

#### C. DESCRIPTION

Surface mounted Cylinder with dimmable LED module and optional integral driver. Adjustable Cylinders feature 90° tilt and 365° lockable rotation during mounting. Pendant Cylinders feature field-cutttable cable (section H, page 13), and dropkits feature field-cutttable stem. (section E, page 6).

#### D. MOUNTING

Adjustable Cylinders may be wall mounted in either Wet (down only) or Dry / Damp locations. Pendant and Stem /Drop Kit Cylinders accommodate flat or sloped ceiling conditions, but may only be installed in dry/damp locations.

Adjustable Wallwash CYX-AW:

Recommended spacing is 36" (914mm) on center with 36" (914mm) setback from wall plane with 30° tilt.

Wallwash Unibody CYX-WW:

Recommended spacing is 48" (1213mm) on center with 48" (914mm) setback from wall plane.

**CY0X/1X/2X/3X-JBMP:**

Specified to mount flush with minimalist transition to standard j-box installed behind substrate (section D.1, page 2).

**CY0X/1X/2X/3X-SMK:**

Includes concealer plate to conceal mounting hardware between fixture and j-box for existing installations (section D.2, page 3).

**CY1X/2X/3X-CMJB:**

Lucifer designed ceiling mount j-box for 1/2" and 3/4" direct conduit feed and provide minimalist transition from Cylinder to j-box (section D.3, page 4). Dry / Damp (IP54) location only.

## D.1 CY0X/1X/2X/3X-JBMP

NOTE: JBMP (A) must be installed prior to substrate.

### PARTS IDENTIFICATION

Part ID	Description	Qty.
A	J box mounting plate	1
B	Mounting adaptor (pendant)	1
B	Mounting adaptor (surface)	1

### Mounting hardware to ship with every fixture:

- #5-32x0.5" FHCS Phillips Drive (PH01-102) for CMJB's.
- #6-32x0.75" FHCS Phillips Drive (PH01-128) for JBMP's/SMK's

### Mounting Tool to ship with every 4 fixtures:

- CY1X ADJ/FB/WW: PH52-045
- CY3 ADJ/FB/WW: PH52-046

## STEP 1

Universal junction box mounting plate attaches to standard 4" octagon or 4" square junction box before ceiling substrate is installed.

NOTE: Max 3/4" ceiling thickness substrate.

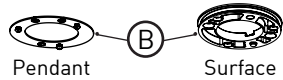
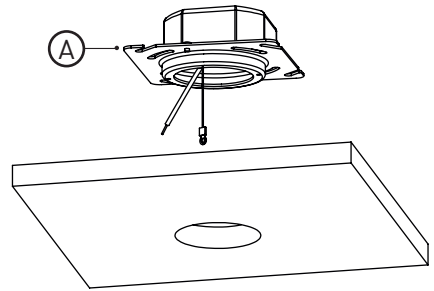

PH52-045/046



Junction box  
(supplied by others)

Junction box  
mounting plate

Ceiling  
substrate

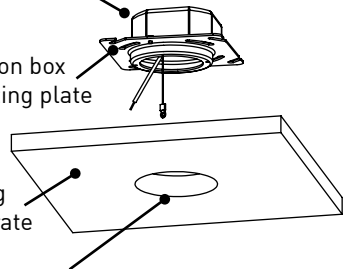

CY0X: 1-1/2" (31mm) cutout  
CY1X: 2-1/8" (54mm) cutout  
CY2X: 2-3/4" (70mm) cutout  
CY3X: 2-3/4" (70mm) cutout

## STEP 2

Attach applicable mounting adaptor with screws provided; ensuring it is seated firmly to the finished ceiling plane by tightening screws.

Please refer to section F, page 10 of this install guide for Cylinder wiring and mounting instructions.

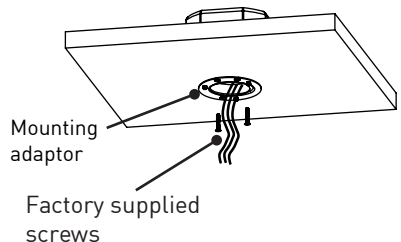

## D.2 CY0X/1X/2X/3X-SMK

### PARTS IDENTIFICATION

Part ID	Description	Qty.
A	Mounting plate	1
B	Concealer plate	1
C	Mounting adaptor (pendant)	1
C	Mounting adaptor (surface)	1

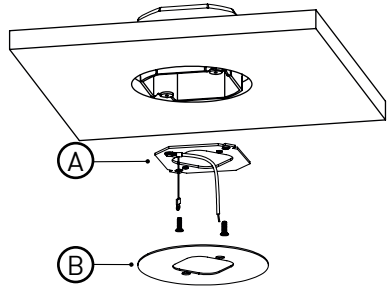

### Mounting hardware to ship with every fixture:

- #5-32x0.5" FHCS Phillips Drive (PH01-102) for CMJB's.
- #6-32x0.75" FHCS Phillips Drive (PH01-128) for JBMP's/SMK's

### Mounting Tool to ship with every 4 fixtures:

- CY1X ADJ/FB/WW: PH52-045
- CY3 ADJ/FB/WW: PH52-046

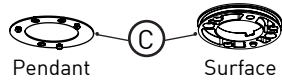

PH52-045/046

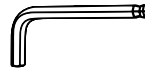

NOTE: Applicable mounting adaptor ships with cylinder assembly.

### STEP 1

The SMK kit is specified for mounting to either standard 3" octagon or standard 4" octagon junction boxes. Remove existing fixture and mounting hardware, ensuring the ceiling area is level and free from debris.

### STEP 2

Attach mounting plate to junction box with screws supplied, routing safety lanyard, and line/ mains supply and control wires through opening.

NOTE: The mounting plate must not extend below the finished ceiling plane.

NOTE: Thicker ceiling substrates may require longer screws. Use 8-32 machine screws with an 82° countersink angle.

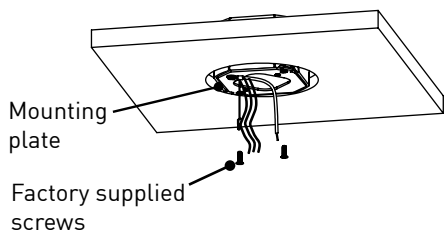
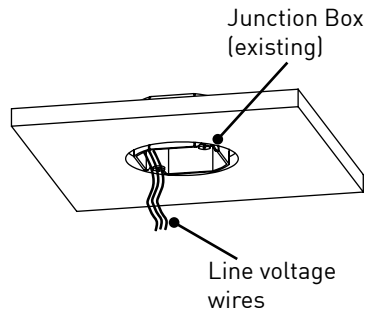

### STEP 3

Attach concealer plate and applicable mounting adaptor with provided screws, ensuring the plates seat firmly to the finished ceiling plane by tightening screws as required.

Please refer to section F, page 10 of this install guide for Cylinder wiring and mounting instructions.

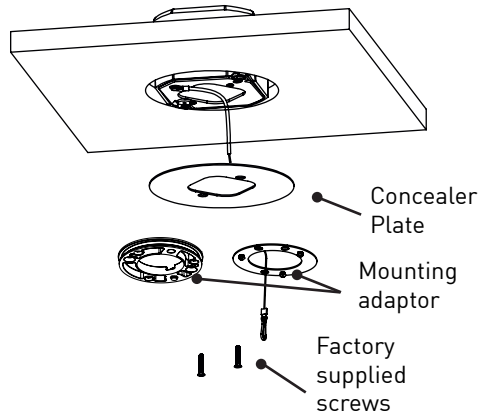

### D.3 CY1X/2X/3X-CMJB

#### PARTS IDENTIFICATION

Part ID	Description	Qty.
A	CY0/1/2/3-CMJB-	1
B	Blank-off plug	2
C	Ground screw	1
D	Clamp	2
E	Clamp screws	4
F	Conduit locking screw	2
G	Mounting plate	1
H	Mounting plate screws	2
I	Safety lanyard	1

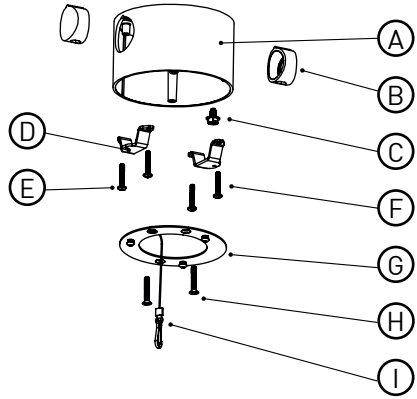

#### Mounting hardware to ship with every fixture:

- #5-32x0.5" FHCS Phillips Drive (PH01-102) for CMJB's.
- #6-32x0.75" FHCS Phillips Drive (PH01-128) for JBMP's/SMK's

#### Mounting Tool to ship with every 4 fixtures:

- CY1X ADJ/FB/WW: PH52-045
- CY3 ADJ/FB/WW: PH52-046

PH52-045/046



NOTE: Mounting Plate "G" used in place of mounting plates shipped with pendant fixtures.

### STEP 1A - 3/4" CONDUIT

For 3/4" conduit, remove mounting plate, loosen clamps and conduit locking screw, discard applicable blank-off plug(s).

NOTE: Maximum 3/4" conduit throat diameter is 0.819" (20.8 mm), per UL code.

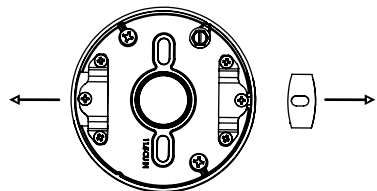

## STEP 1B - 1/2" CONDUIT

Scan QR code and reference knock-out removal video. Loosen clamp and locking screw to remove plug(s). On a protected concrete surface, remove knock-out from plug using 1/2" conduit and reinstall in reverse orientation.

NOTE: Maximum 1/2" conduit throat diameter is 0.622" (15.8 mm), per UL code.

### Knock-out Removal

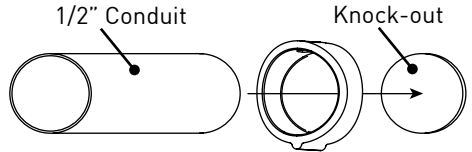
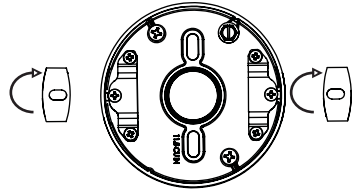

## STEP 1C - TOP FEED

Remove the mounting plate, place CMJB on a soft surface and remove top knock out.

### Knock-out

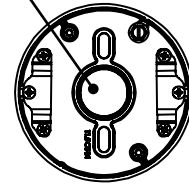

## STEP 2

Ensure the ceiling area is level and free from debris, secure j-box to ceiling.

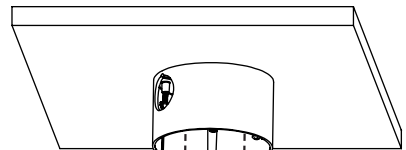

Screws  
(supplied  
by others)

## STEP 3

Run conduit and / or wiring to the CMJB. On applications using conduit tighten clamp screws and conduit locking screw. Install mounting plate or mounting adaptor as applies.

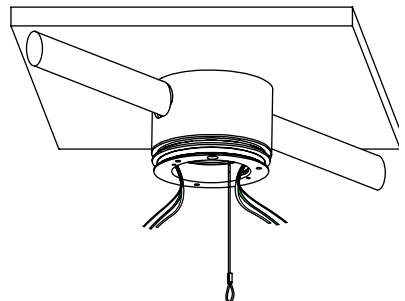

Please refer to section G, page 11 of this install guide for Cylinder wiring and mounting instructions.

## E. CY0X/1X/2X/3X-DK (DROP KIT)

For suspending cylinder at varying heights and on sloped ceilings up to 45°. Must be installed in conjunction with the JBMP (Section D.1), SMK (Section D.2) or CMJB (Section D.3).

NOTE: The CY0X/1X/2X/3X-JBMP must be installed prior to substrate.

### PARTS IDENTIFICATION

Part ID	Description	Qty.
A	Mounting plate	1
B	Mounting plate screws	2
C	Pressure plate	1
D	Ball swivel	1
E	Magnetic concealer plate	1
F	Stem	1-3
G	Lower canopy	1
H	Safety lanyard	1
I	Retaining collar	1
J	Set Screws	3
K	Threaded Nipple	1-2
L	Clamping bracket	1
M	Clamping bracket screw	1

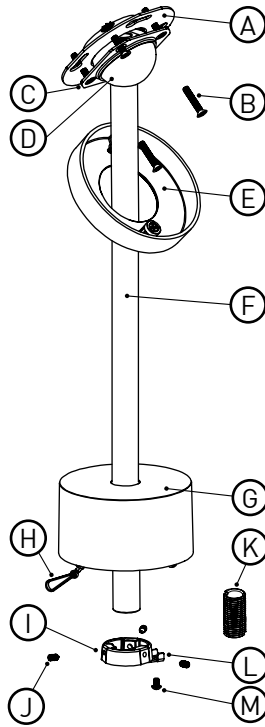

### Mounting hardware to ship with every fixture:

- #5-32x0.5" FHCS Phillips Drive (PH01-102) for CMJB's.
- #6-32x0.75" FHCS Phillips Drive (PH01-128) for JBMP's/SMK's

### Mounting Tool to ship with every 4 fixtures:

- CY1X ADJ/FB/WW: PH52-045
- CY3 ADJ/FB/WW: PH52-046

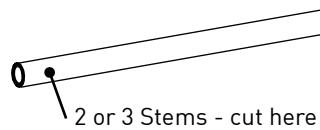
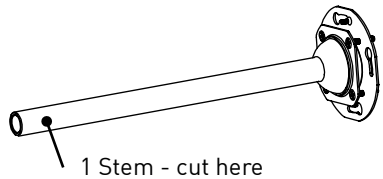

## STEP 1

Cut stem to length as required at 90° angle from end where the lower canopy will be connected.

Installer Tip: Stem is recessed into lower canopy 3/8", add 3/8" to total length prior to cutting stem.

## STEP 2

Connect stems as required by threading stems together.

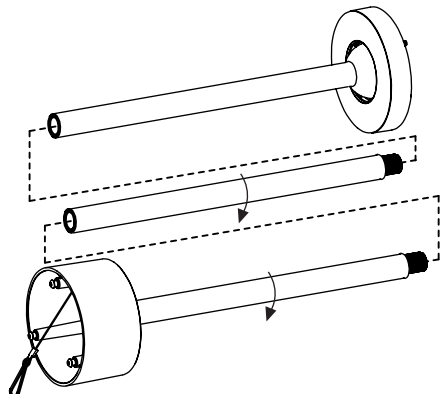

### STEP 3

Feed line and control wiring (if required) through stem(s) from the mounting plate to the lower canopy; wiring supplied by others. See wiring requirements in Section 0.

Installer Tip: Recommend using solid 12 AWG THHN and 18/2 for line voltage and control wiring. Wrap wiring tight with electrical tape and push through stems.

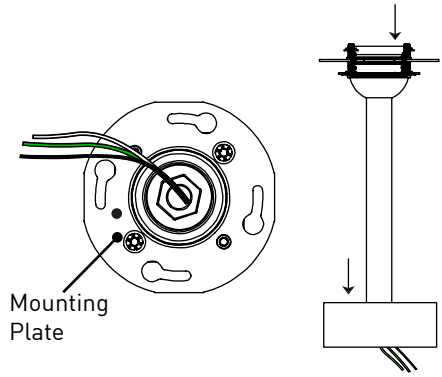

### STEP 4

Ensure magnetic concealer plate is in place and feed lower canopy onto stem, install retaining collar on end of stem and secure with three factory supplied set screws. Ensure bushing is secured to stem.

WARNING: Failure to ensure set screws are adequately tightened may result in failure of bushing.

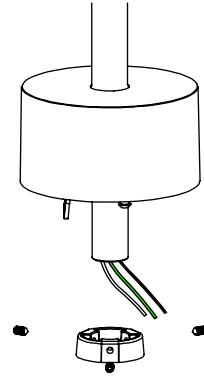

### STEP 5

Install clamping bracket to lower canopy by starting supplied screw, rotate bracket over retaining collar and tighten screw.

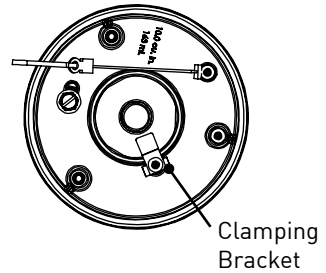

### STEP 6

Remove the three 5/64" mounting standoffs and install the mounting adaptor (shipped with fixture) with three supplied 5/64" screws.

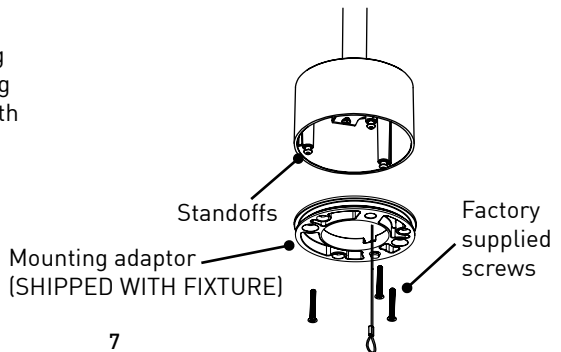

## STEP 7

Loosen pressure plate screws slightly prior to installation.

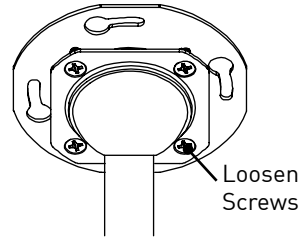

## STEP 8

Attach safety lanyard and wiring from line / mains source as indicated with suitable wire-nuts or similar connectors. For 0-10V dimming option, use gray and purple wires as shown. Push connections, excess wiring, and lanyard into junction box.

NOTE: CMJB application not shown.

Black Wire	= Line
White	= Neutral
Green	= Ground
Purple	= Dim +
Gray	= Dim -

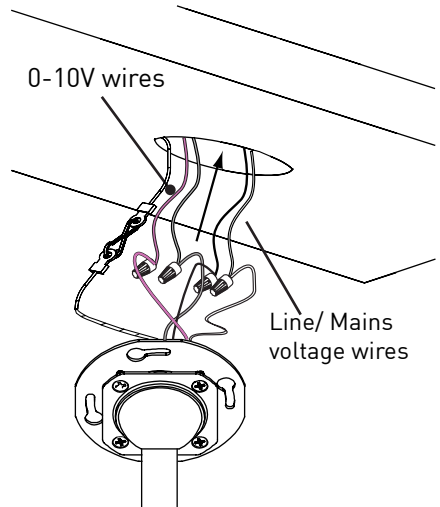

## STEP 9

Attach drop kit mounting plate to applicable mounting option using supplied screws.

### 9.1 CY0X/1X/2X/3X-JBMP

Reference section D.1 for complete JBMP installation instructions. Position drop kit mounting plate below ceiling cutout and attach to J-box mounting plate with supplied screws.

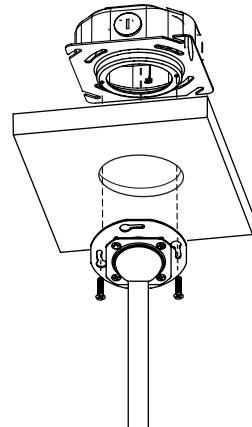



## 9.2 CY0X/1X/2X/3X-SMK

Reference section D.2 for complete SMK installation instructions. With SMK mounting plate installed, feed supplied screws through drop kit mounting plate and concealer plate and attach to SMK mounting plate.

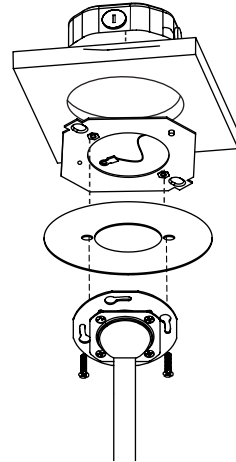

## 9.3 CY1X/2X/3X-CMJB

Reference section D.3 for complete CMJB installation instructions. Remove factory supplied mounting plate from CMJB and attach drop kit mounting plate with original screws.

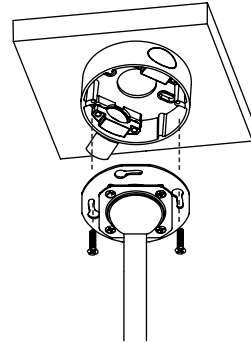

## STEP 10

With drop kit installed and stem positioned vertically, UNIFORMLY tighten pressure plate screws and raise magnetic concealer plate.

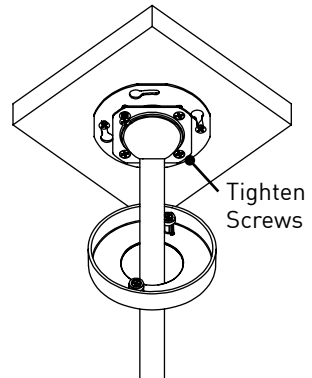

## F. WIRING & MOUNTING

If using remote power supply, see Section G.

### STEP 1

Back out 3/32" hex set screw on canopy six full turns, ensuring it is not removed completely.

Installers Note: Using a Ball End Hex Key tool is recommended.

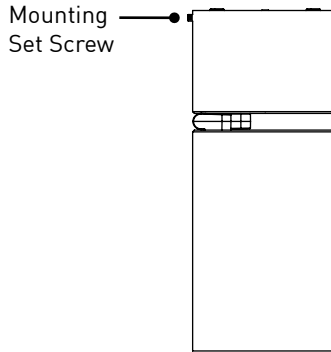

### STEP 2

Install mounting adaptor using respective screws, then connect Cylinder to safety lanyard mounting screw.

**WARNING: Failure to attach safety lanyard may result in an unsafe condition.**

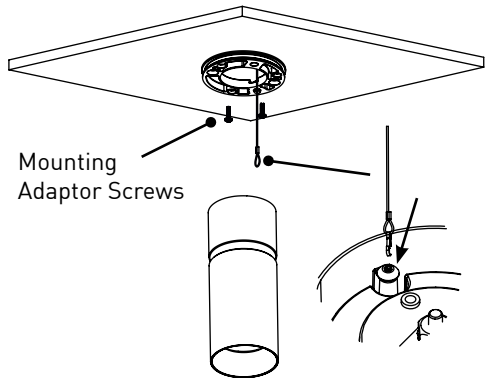

### STEP 3A - UL1598 INSTALLATIONS

Attach wiring from line / mains source as indicated with suitable wire-nuts or similar connectors. For 0-10V dimming option, use purple and gray wires. Push connections, excess wiring, and lanyard into junction box.

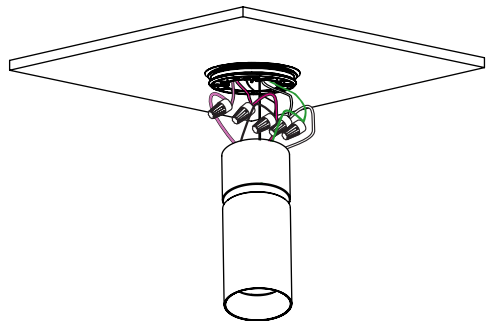

#### INTEGRAL DRIVER WIRING

Black = Line  
White = Neutral  
Green = Ground  
Purple = Dim +  
Pink = Dim -

## STEP 3B - UL2108 INSTALLATIONS

Attach wiring from low voltage source as indicated with suitable wire-nuts or similar connectors.

Reference Section P for drive current and node compatibility information.

### CY0X/1X/2X/3X AD/FB/WW

- (+) - Red (+)
- (-) - Black (-)

### CP2X/CP3X/CP3XU

**DOWNLIGHT**                      **UPLIGHT**

- (+) - Red (+)                      (+) - White (+)
- (-) - Blue (-)                    (-) - Black (-)

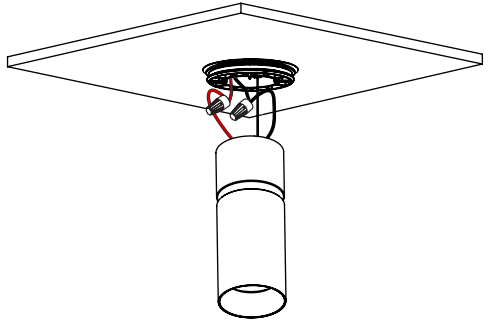

## STEP 4

With fixture at slight angle, key mounting lip into the upper groove of the adaptor, being careful to not mar the ceiling. With lip engaged, tilt the cylinder canopy up and flush with ceiling or CMJB.

NOTE: For CPX Fixtures, align three keyholes of Cylinder with standoffs of mounting adaptor plate, turning clockwise to fully secure.

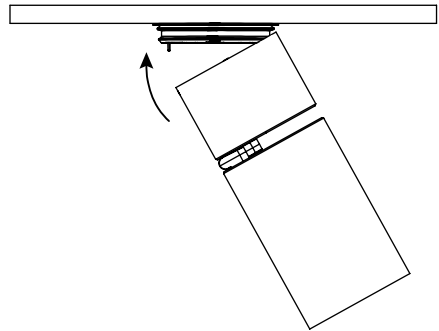

Upper Groove —●—

Lower Groove —●—

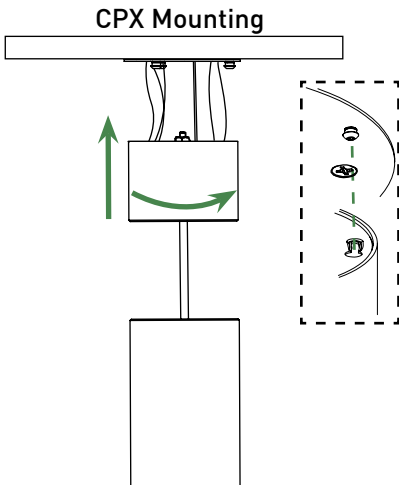
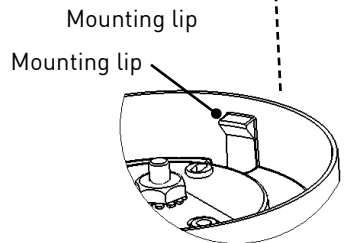

## STEP 5

Tighten the mounting set screw until secured onto the lower groove of the mounting adaptor. For aiming, loosen mounting set screw slightly to facilitate rotation.

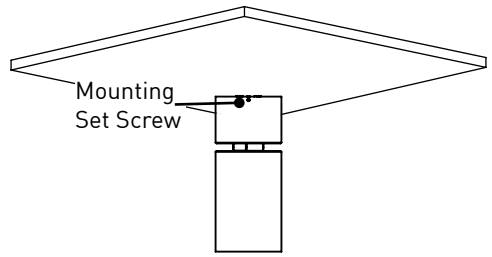

## STEP 6

Rotate and aim adjustable fixtures to achieve desired effect. Lock mounting set screw when aiming is complete.

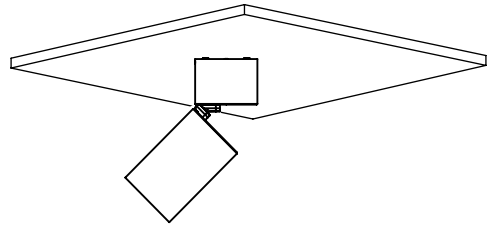

## F. WALLWASH INSTALLATIONS

Factory recommends 36" x 36" setback and spacing for adjustable fixtures, and 48" x 48" wallwash unibody fixtures.

### STEP 1

Install fixture with set screw facing desired wallwash surface (unibody only).

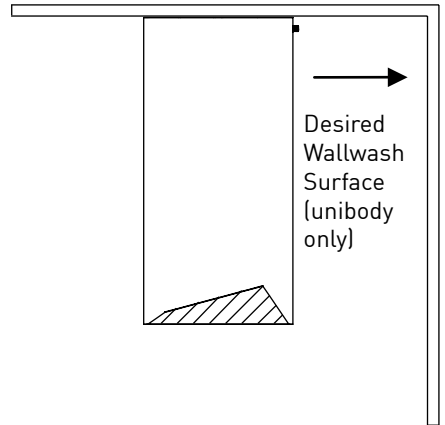

## G. WET LOCATION INSTALLATIONS (IP54 & IP55)

Do not apply caulking to fixture until aiming is completed.

### STEP 1

With fixture aiming completed, apply a fillet seal around the fixture canopy mounting surface.

### STEP 2

Apply caulk to the set screw.

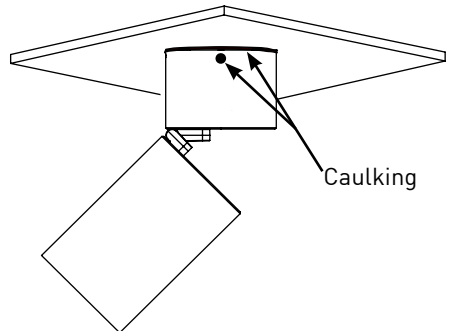

## H. PENDANT CABLE ADJUSTMENT

### STEP 1

Disconnect quick connectors from pendant side. If applicable, loosen driver assembly screws and rotate assembly counter clockwise to remove.

**NOTE:** Up-Down pendant features two pairs of low-voltage wiring feeding into pendant cable.

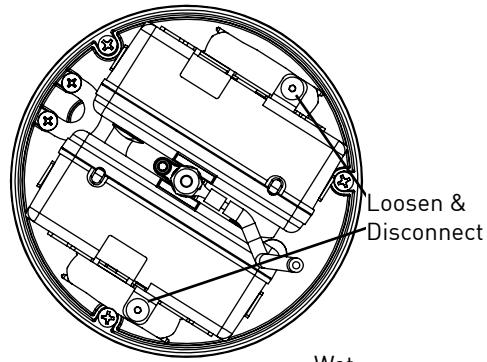

### STEP 2

Loosen cable retainer screws and slide retainer off of cable. Remove wet location retainer if applicable, leaving it on the cable.

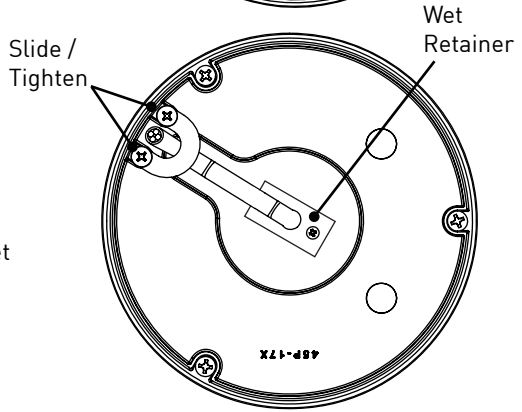

### STEP 3

Set cable to desired length, positioning cable in canopy as shown.

Cut cable 6" from base of inner canopy. Strip 4" back after cutting, leaving excess wiring to make wiring connections.

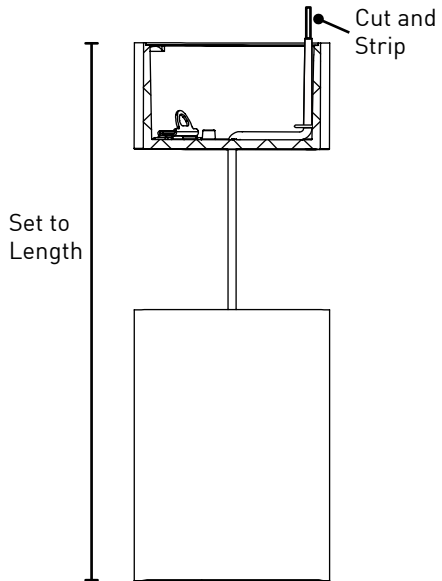

## STEP 5

Reinstall wet location retainer as applies and slide cable retainer over cable, tighten screws to secure.

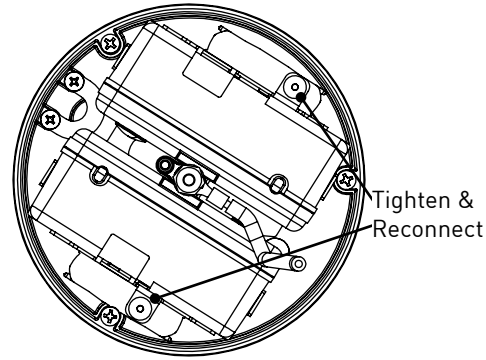

## STEP 6

Reinstall driver assembly if applicable, by turning clockwise onto screws and tightening. Reattach low voltage conductors, referring to the chart below:

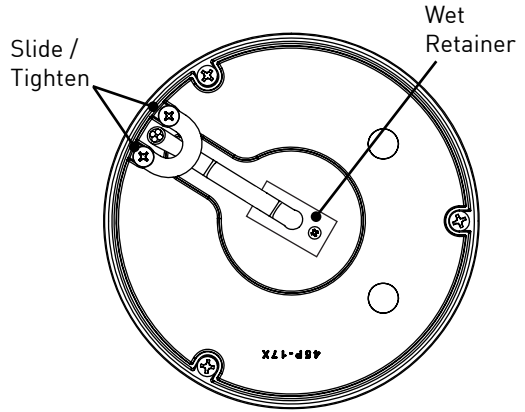

## WIRING DIAGRAM

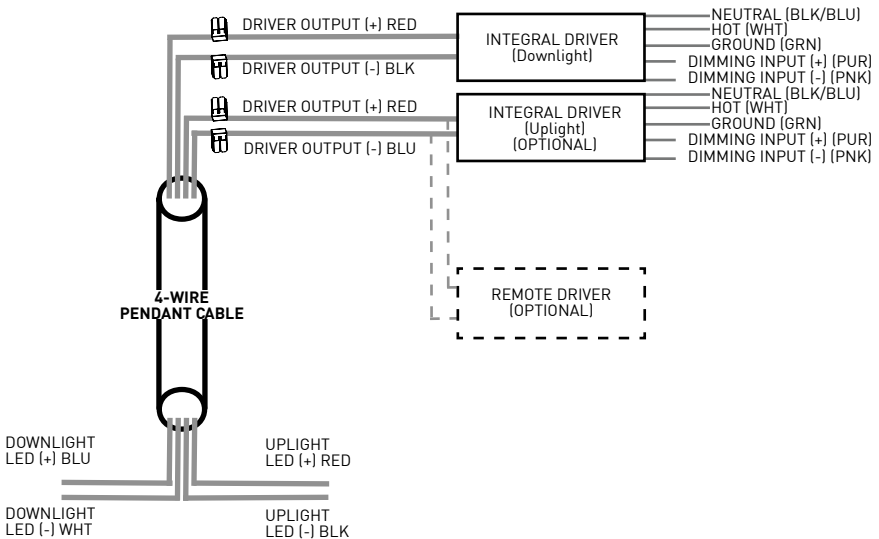

## I. REMOTE POWER SUPPLY - UL1598 INSTALLATIONS ONLY

Determine preferred mounting location, verifying that fixture falls within maximum allowed wiring distance (Fig. 1).

Run adequately sized two-pair wire between remote driver and housing, following installation guidelines for terminating as needed.

**Note:** Secondary wiring is polarized (+/-) and must be terminated correctly at both ends for proper operation. It is recommended to use Red (+) and Black (-) wires to avoid confusion. No ground wire necessary on secondary side.

*Ensure proper polarity is observed as reversed polarity may damage the unit and may void the warranty.*

Access splice compartment by removing retaining screws, then tilting cover slightly back and away from base (Fig.2).

Mount power supply back plate assembly to suitable substrate using customer-supplied screws (Fig.3).

Insert line voltage wiring/conduit into line side of splice compartment and secondary voltage wiring/conduit into secondary side of splice compartment, utilizing appropriate strain relief or connector.

**Note:** Consult wiring diagrams on page 16 for applicable driver type.

Join structured building wires to corresponding driver wires with suitable customer-supplied wire connecting device.

Push all wires and wire connections into splice compartment and reinstall splice compartment cover by aligning tab and slot, ensuring that no wires are pinched by cover. Install retaining screws (Fig.3).

**Important:** Ensure foam aperture insert is in place prior to commencing ceiling installation. Failure to comply may result in damage to the LED or optic.

### Standard Drivers: "URA" & "URE"

AWG Value	20	18	16	14
Distance (m)	12	20	32	50
Distance (ft)	40	66	105	164

### Lutron Drivers: "L2" & "LH"

AWG Value	18	16	14	12
Distance (m)	4.5	7.5	12	18
Distance (ft)	15	25	40	60

### Philips Drivers: "TR", "AN", & "LN"

AWG Value	20	18	16	14	12
Distance (m)	14	22	34	55	87
Distance (ft)	45	71	113	180	285

### eldoLED Drivers: "ED", "LD", "LA", "EA"

AWG Value	20	19	18	17	16
Distance (m)	14	18	22	28	36
Distance (ft)	46	59	72	92	118

Fig.1

Min. 8" feed wires in splice compartment

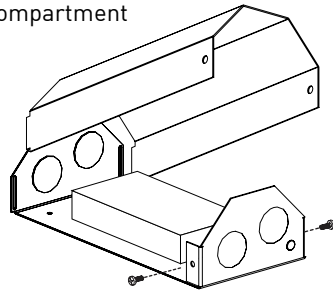

Fig.2

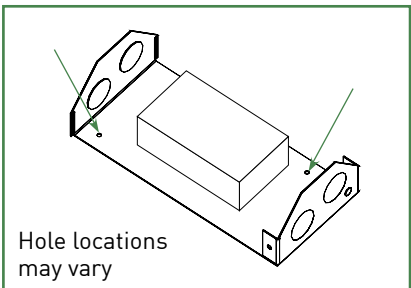

Fig.3

## J. EFFECTS DEVICE REPLACEMENT

### STEP 1

Grasp inner lip of baffle assembly and carefully pull down to remove.

### STEP 2

To access effects device, pinch spring tabs and remove.

Note: Fixture can accommodate up to two effects devices.

### STEP 3

With effects device(s) installed, reinstall lens retainer to baffle base in opposite order of removal.

### STEP 4

Carefully reinstall baffle assembly by pushing up into fixture.

**Note:** For wet location fixtures (IP54 or IP55), a new baffle subassembly must be ordered.

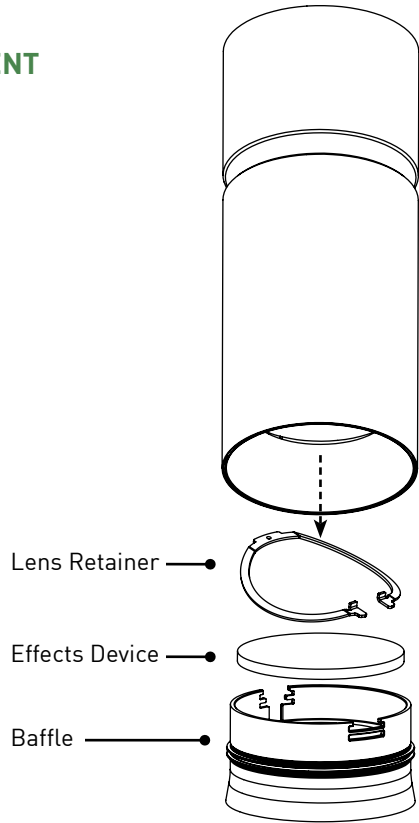

## K. OPTIC REPLACEMENT

### STEP 1

Grasp inner lip of baffle and carefully pull down to remove.

### STEP 2

Turn optic assembly counter clockwise and pull down to remove from fixture.

### STEP 3

Install optic assembly by aligning locking tabs of assembly with LED base, turning clockwise.

### STEP 4

Carefully reinstall baffle assembly by pushing up into fixture.

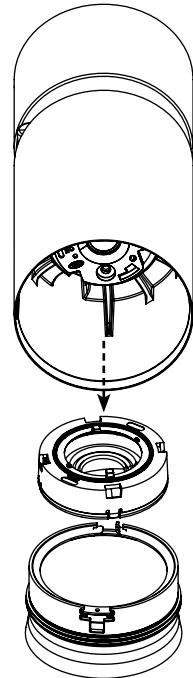



## L. INTEGRAL DRIVER REPLACEMENT

### STEP 1

Loosen 3/32" Allen screw and remove fixture from mounting adaptor.

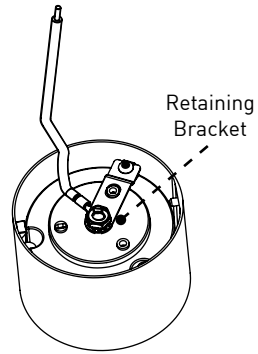

### STEP 2

Disconnect line/mains and control wiring from driver as applies.

### STEP 3

Remove driver retaining bracket and then the driver from fixture canopy. Disconnect quick connectors below driver.

### STEP 4

Reconnect connectors and install replacement driver. Secure retaining bracket with two screws.

**Note:** Connectors will be quick-connectors for adjustable fixtures, and WAGO for pendants.

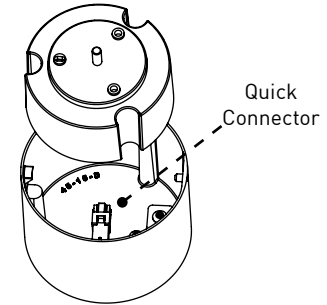

### STEP 5

Reconnect secondary voltage wiring to line/mains and control wiring to driver as applies. See diagram below.

Line / Mains and Control Voltage:

#### LINE / MAINS & CONTROL VOLTAGE

Black - Line  
White - Neutral  
Green - Ground  
Purple - Dim +  
Pink - Dim -

Secondary LED Voltage:

#### SECONDARY LED VOLTAGE

Red (+) - Red (+)  
Blue (-) - Black (-)

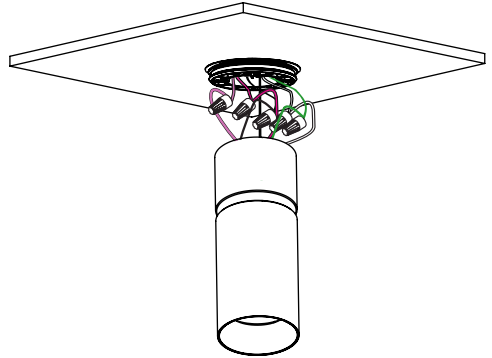

### STEP 6

Reference section F for fixture reinstallation.

## M. LED REPLACEMENT

### STEP 1

With baffle and optic removed, remove 1/16" Allen screws from LED holder.

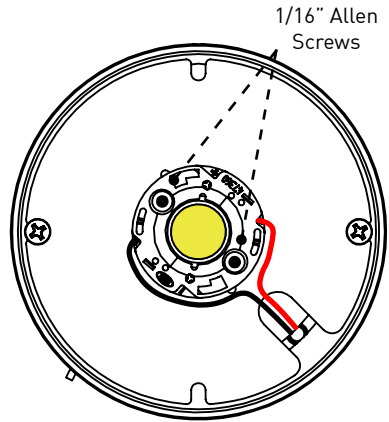

### STEP 2

Lift LED holder away from base and push LED out of holder.

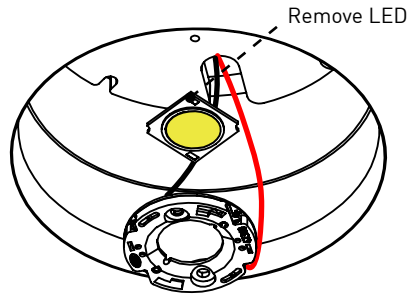

### STEP 3

Insert new LED into back of holder ensuring polarity is aligned. Red (+), Black (-).

#### **IMPORTANT:**

*Ensure proper polarity is observed as reversed polarity may damage the unit. This will void warranty and fixture will not function.*

#### **IMPORTANT:**

*Take care not to touch / mar yellow LED surface.*

Install LED

A side view of the LED holder being placed back onto the base. A red arrow points to the LED being inserted into the holder. The label "Install LED" is positioned below the holder.

### STEP 4

Place LED holder onto base and install 1/16" Allen screws. Tighten screws until resistance is felt and tighten additional 1/4 turn.

#### **IMPORTANT:**

*Ensure LED holder screws are adequately tightened. Under or over tightening will void warranty.*

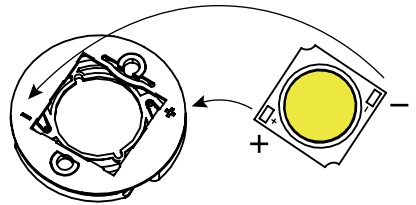

### STEP 5

Install optic and baffle.

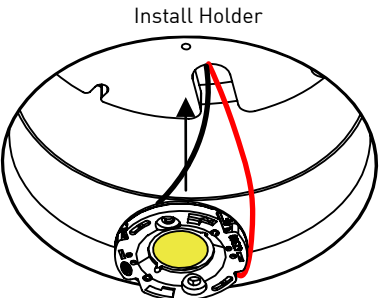

## N. DRIVER WIRING DETAIL

### GENERAL WIRING NOTES

1. Consult approved dimmer list to ensure compatibility.
2. Install in accordance with manufacturer's dimmer installation guidelines.
3. Secondary and 0-10V connections are polarity sensitive.

### WIRING DIAGRAM FOR PHASE DIMMING

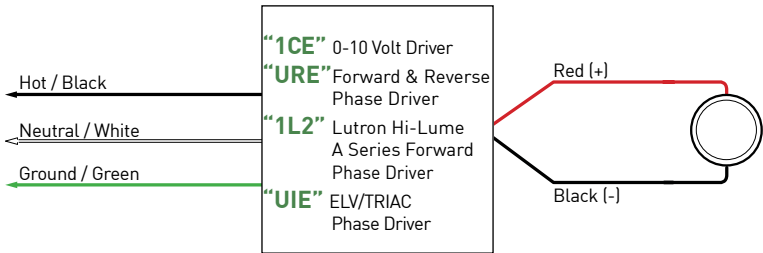

### WIRING DIAGRAM FOR ECOSYSTEM AND DIGITAL CONTROL

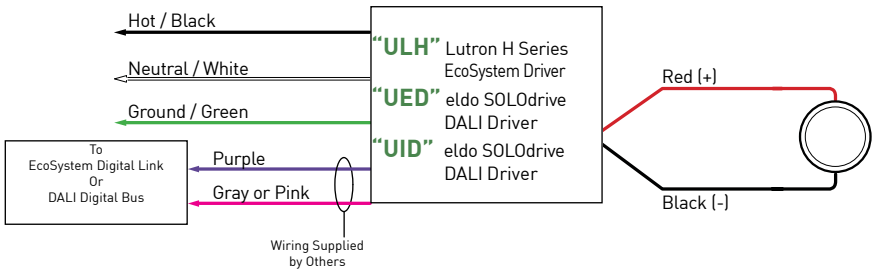

### WIRING DIAGRAM FOR ANALOG CONTROL

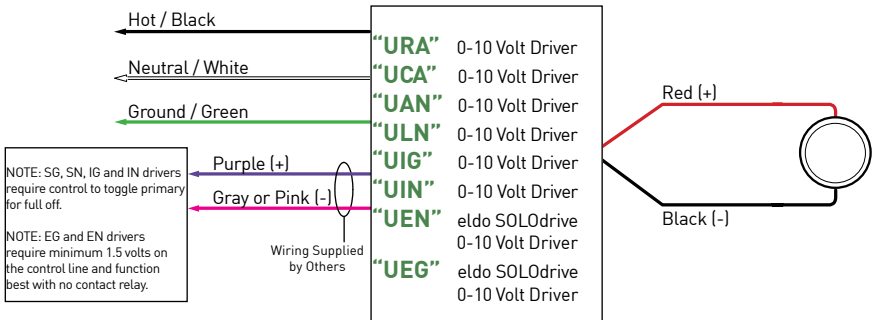

## WIRING DIAGRAM FOR TUNABLE WHITE ANALOG CONTROL

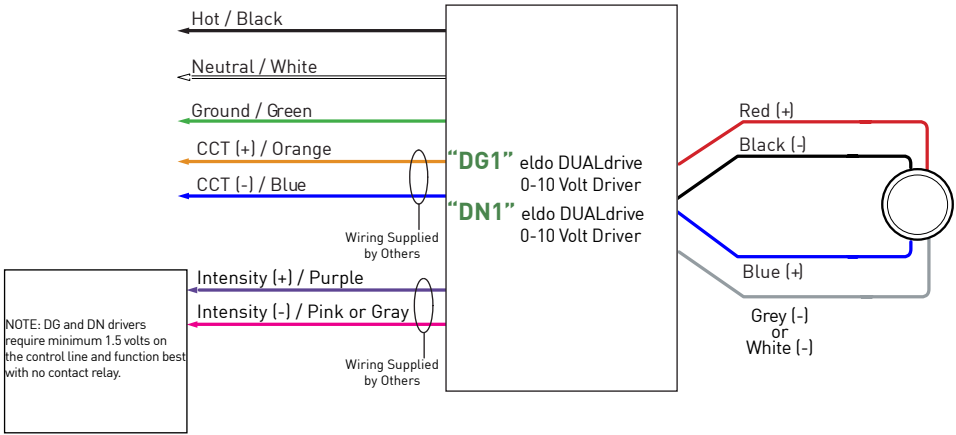

## WIRING DIAGRAM FOR TUNABLE WHITE DALI CONTROL

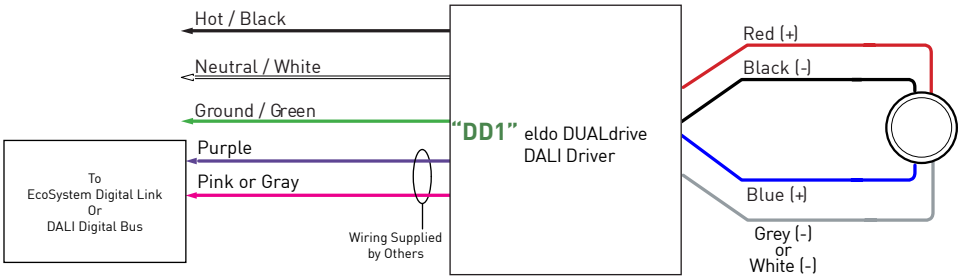

# WIRING DIAGRAM FOR PENDANT UP-DOWN ANALOG CONTROL

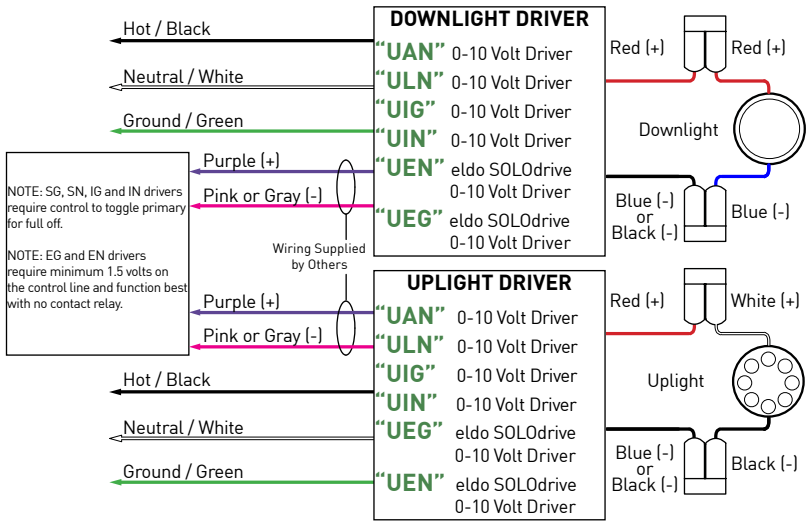

## MAXIMUM ALLOWABLE WIRING DISTANCES

### Standard Drivers: "URA" & "URE"

AWG Value	20	18	16	14
Distance (m)	12	20	32	50
Distance (ft)	40	66	105	164

### Philips Drivers: "TR", "AN", & "LN"

AWG Value	20	18	16	14	12
Distance (m)	14	22	34	55	87
Distance (ft)	45	71	113	180	285

### Lutron Drivers: "L2" & "LH"

AWG Value	18	16	14	12
Distance (m)	4.5	7.5	12	18
Distance (ft)	15	25	40	60

### eldoLED Drivers: "ED", "LD", "LA", "EA"

AWG Value	20	19	18	17	16
Distance (m)	14	18	22	28	36
Distance (ft)	46	59	72	92	118

## O. STEM WIRING REQUIREMENTS

INTEGRAL DRIVER	LINE VOLTAGE / CONTROL WIRING
CE	QTY. 3 #14-#12 BLACK, WHITE & GROUND
CA	QTY. 3 #14-#12 BLACK, WHITE & GROUND QTY. 2 #18 GRAY (-) & PURPLE (+)

REMOTE / LVS / POE	CLASS 2 WIRING
URA/URE	QTY. 2 #14-#12 BLACK (-) & RED (+)
1TR	QTY. 2 #14-#12 BLACK (-) & RED (+)
1L2	QTY. 2 #14-#12 BLACK (-) & RED (+)
UAN	QTY. 2 #14-#12 BLACK (-) & RED (+)
ULN	QTY. 2 #14-#12 BLACK (-) & RED (+)
UEA	QTY. 2 #14-#12 BLACK (-) & RED (+)
UEN	QTY. 2 #14-#12 BLACK (-) & RED (+)
ULH	QTY. 2 #14-#12 BLACK (-) & RED (+)
UED	QTY. 2 #14-#12 BLACK (-) & RED (+)
ULD	QTY. 2 #14-#12 BLACK (-) & RED (+)
LVS / POE	QTY. 2 #14-#12 BLACK (-) & RED (+)



## P. UL2108 INSTALLATION INFORMATION

### Drive Current Information:

	80S						90S					
	11B	14D	17B	24B	32B	39B	11B	14D	17B	24B	32B	39B
Minimum Vf	30.5	30.5	30.5	30.5	30.5	30.5	30.5	30.5	30.5	30.5	30.5	30.5
Maximum Vf	36.2	37	36.2	36.2	36.2	36.2	36.2	37	36.2	36.2	36.2	36.2
Current mA	250	300	400	550	750	900	250	300	400	550	750	900
Wattage W	11	14	17	24	32	39	11	14	17	24	32	39

	95/97S						90W				
	11B	14D	17B	24B	32B	39B	13D	15AD	15AL	19A	40E
Minimum Vf	30.5	30.5	30.5	30.5	30.5	30.5	30.5	30.5	30.5	30.5	30.5
Maximum Vf	36.2	37	36.2	36.2	36.2	36.2	38.6	37.7	37.7	37.7	37.7
Current mA	250	300	400	550	750	900	250	250	250	300	900
Wattage W	11	14	17	24	32	39	13	15	15	19	40

### Node Compatibility:

Manufacturer	Model Number
 Enabling Smart Buildings™	NP50-60-C-F-5
	180996-1001 180996-1002 180996-2001 180996-2002
	1 Channel Node, POE-ULN-1U-E 2 Channel Node, POE-ULN-2U-E 4 Channel Node, POE-ULN-4U-E

Please consult website for full warranty terms and conditions:

[www.luciferlighting.com/warranty](http://www.luciferlighting.com/warranty)

[11132023]

3750 North PanAm Expressway

San Antonio, TX 78219 USA

[PH] +1 210 227 7329

[FAX] +1 210 227 4967

[www.luciferlighting.com](http://www.luciferlighting.com)